



ExtraNET CC,  
ExtraNET Avalanche,  
and  
ExtraNET  $\mu$ CC

**User Manual and Integrator Documentation**

© 2006-2008 Crystalline Technology, Inc.

REVISION TRACKING SHEET

**THIS MANUAL MAY BE REVISED PERIODICALLY TO INCORPORATE NEW OR UPDATED INFORMATION. THE DATE REVISION LEVEL OF EACH PAGE IS INDICATED AT THE BOTTOM OF THE PAGE ALONG WITH THE PAGE NUMBER. A MAJOR CHANGE IN THE CONTENT OF THE MANUAL ALSO CHANGES THE DATE OF THE MANUAL, THAT APPEARS ON THE FRONT COVER. LISTED BELOW IS THE DATE REVISION LEVEL OF EACH PAGE.**

PAGE	REVISION	DATE	DESCRIPTION
All	Preliminary	1/12/06	Preliminary Documentation
All	Rev 0.1	10/31/06	Initial Public Release
All	Rev 0.2	11/20/06	Added safety warnings for Div 2 application
All	Rev 0.3	02/17/08	Added sections for Avalanche and $\mu$ CC

**© CRYSTALLINE TECHNOLOGY INC. 2003-2008. ALL RIGHTS RESERVED.**

**EXTRANET CC, EXTRANET AVALANCHE, AND EXTRANET  $\mu$ CC ARE A TRADEMARKS OF CRYSTALLINE TECHNOLOGY, INC. ALL OTHER MARKS ARE THE PROPERTY OF THEIR RESPECTIVE OWNERS.**

**PRINTED IN THE U.S.A.**

**WHILE INFORMATION IS PRESENTED IN GOOD FAITH AND BELIEVED TO BE ACCURATE, CRYSTALLINE TECHNOLOGY DOES NOT GUARANTEE SATISFACTORY RESULTS FROM RELIANCE ON SUCH INFORMATION. *NOTHING* CONTAINED HEREIN IS TO BE CONSTRUED AS A WARRANTY OR GUARANTEE, EXPRESS OR IMPLIED, REGARDING THE PERFORMANCE, MERCHANTABILITY, FITNESS OR ANY OTHER MATTER WITH RESPECT TO THE PRODUCTS, NOR AS A RECOMMENDATION TO USE ANY PRODUCT OR PROCESS IN CONFLICT WITH ANY PATENT. CRYSTALLINE TECHNOLOGY, INC. RESERVES THE RIGHT, WITHOUT NOTICE, TO ALTER OR IMPROVE THE DESIGNS OR SPECIFICATIONS OF THE PRODUCTS DESCRIBED HEREIN.**

# TABLE OF CONTENTS

<b>INTRODUCTION</b> .....	<b>4</b>
<b>RECITALS</b> .....	<b>4</b>
1. DEFINITIONS .....	4
2. GRANT OF LICENSE .....	4
3. TERMINATION .....	5
4. COPYRIGHT .....	5
5. APPLICABLE LAW .....	5
6. WARRANTIES AND LIMITATION ON LIABILITY .....	5
6.1 ONE-YEAR LIMITED WARRANTY .....	5
This is Crystalline Technology, Inc.'s exclusive written warranty.....	6
<b>QUICK START</b> .....	<b>7</b>
<b>INTRODUCTION TO THE EXTRANET</b> .....	<b>9</b>
Features .....	9
Overview .....	10
<b>CONNECTION TO EXTERNAL EQUIPMENT</b> .....	<b>11</b>
<b>DIAGNOSTIC CABLE</b> .....	<b>14</b>
<b>CONFIGURATION</b> .....	<b>15</b>
Configuration Menu .....	15
D) Display Settings.....	15
L) List Event Log .....	16
C) Connect to Globalstar gateway.....	16
H) Hangup Globalstar Modem.....	16
B) Reset ExtraNET CC.....	17
G) Configure Globalstar Modem .....	17
R) Show Communication Status .....	17
S) Test BSAP Connection.....	17
T) Test ROC Connection .....	18
F) Configure ExtraNET CC Mode .....	18
G) Configure Globalstar Modem .....	20
W) Configure Wireless Modem.....	21
R) Show Communication Status .....	22
<b>USING EXTRANET CC FOR SCADA APPLICATIONS</b> .....	<b>23</b>
Modbus/IP.....	25
<b>VB.NET SAMPLE PROGRAM</b> .....	<b>26</b>
<b>EXTRANET AVALANCHE</b> .....	<b>27</b>
Overview:.....	27
Features:.....	27
Theory of Operation .....	28
<b>GETTING READY TO USE AVALANCHE</b> .....	<b>30</b>

Installation Considerations.....	30
Interfacing RTU .....	30
<b>AVALANCHE MENU AND CONFIGURATION .....</b>	<b>32</b>
Email Attachment Formats .....	38
Binary File - FloBoss.....	38
Comma Delimited File Format – FloBoss .....	42
<b>SMS MESSAGES.....</b>	<b>45</b>
SMS Support Program.....	46
<b>EXTRANET <math>\mu</math>CC OVERVIEW .....</b>	<b>47</b>
ExtraNET $\mu$ CC Configuration .....	49
Obtaining Control of ExtraNET $\mu$ CC.....	50
Installation of ExtraNET $\mu$ CC .....	50
Integrating ExtraNET $\mu$ CC into an application .....	51
ExtraNET $\mu$ CC Wiring Requirements.....	52
<b>APPENDIX A – UL CERTIFICATION .....</b>	<b>54</b>
Special Instructions for Class I, Division 2 Hazardous Locations.....	55
<b>SPECIFICATIONS: .....</b>	<b>56</b>
<b>CONTACT INFORMATION .....</b>	<b>57</b>

## **Introduction**

ExtraNET comes in three different configurations. ExtraNET CC is a complete solution functioning as a “remote terminal server”. The ExtraNET CC contains a TCP/IP and UDP/IP stack and supports a static IP address. ExtraNET CC can also be used to originate a TCP session with a predefined host.

ExtraNET Avalanche is a “store and forward” device that acquires data from the customer’s RTU and at predetermined times, sends this data as an email.

ExtraNET  $\mu$ CC is a legacy product that functions as a dial up modem would. Crystalline Technology has added to the basic functionality of the Globalstar 1620 / 1720 modems by including a processor that restores user configurations in the event of a power loss or reset.

This manual contains information on all three of the products.

## **Recitals**

Use of Crystalline Technology, Inc. (“CTI”) products requires three elements: the SOFTWARE, the hardware, and a personal computer or RTU. The SOFTWARE is protected by copyright laws and international copyright treaties, as well as other intellectual property laws and treaties. The SOFTWARE is not sold, and instead is only licensed for use, strictly in accordance with this document. The hardware is protected by various patents, and is sold, but this agreement does not cover that sale, since it may not necessarily be sold as a package with the SOFTWARE. This agreement sets forth the terms and conditions of the SOFTWARE LICENSE only.

### **1. DEFINITIONS**

1.1 Customer. Customer means the entity or individual that downloads the SOFTWARE.

### **2. GRANT OF LICENSE**

2.1 Rights and Limitations of Grant. Crystalline Technology, Inc. (“CTI”) hereby grants Customer the following non-exclusive, non-transferable right to use the SOFTWARE, with the following limitations:

2.1.1 Rights. Customer may install and use one copy of the SOFTWARE on a single computer, and except for making one back-up copy of the Software, may not otherwise copy the SOFTWARE. This LICENSE of SOFTWARE may not be shared or used concurrently on different computers.

No Reverse Engineering. Customer may not reverse engineer, decompile, or disassemble the SOFTWARE, nor attempt in any other manner to obtain the source code.

No Separation of Components. The SOFTWARE is licensed as a single product. Its component parts may not be separated for use on more than one computer, nor otherwise used separately from the other parts.

No Rental. Customer may not rent or lease the SOFTWARE to someone else.

### **3. TERMINATION**

This LICENSE will automatically terminate if Customer fails to comply with any of the terms and conditions hereof. In such event, Customer must destroy all copies of the SOFTWARE and all of its component parts

### **4. COPYRIGHT**

All title and copyrights in and to the SOFTWARE (including but not limited to all images, photographs, animations, video, audio, music, text, and other information incorporated into the SOFTWARE), the accompanying printed materials, and any copies of the SOFTWARE, are owned by Crystalline Technology, Inc. (“CTI”), or its suppliers. The SOFTWARE is protected by copyright laws and international treaty provisions. Accordingly, Customer is required to treat the SOFTWARE like any other copyrighted material, except as otherwise allowed pursuant to this LICENSE and that it may make one copy of the SOFTWARE solely for backup or archive purposes.

### **5. APPLICABLE LAW**

This agreement shall be deemed to have been made in, and shall be construed pursuant to, the laws of the State of Nevada and / or the United States of America.

### **6. WARRANTIES AND LIMITATION ON LIABILITY**

#### **6.1 ONE-YEAR LIMITED WARRANTY**

Crystalline Technology, Inc. ExtraNET CC is warranted to be free of defects in material and workmanship for one year from date of installation.

Crystalline Technology, Inc. will, at its election, repair, replace or make appropriate adjustment where Crystalline Technology, Inc. inspection discloses any such defects occurring in normal usage within one (1) year after installation. Crystalline Technology, Inc. is not responsible for removal or installation costs.

To obtain warranty service contact Crystalline Technology, Inc. either through your Dealer or by writing Crystalline Technology, Inc., Attn: Customer Service Department, PO Box 8423, Pueblo, CO, USA, or by calling 1-888-737-9817 from within the USA or Canada and 001-719-543-2577 from within Mexico.

**IMPLIED WARRANTIES INCLUDING THAT OF MERCHANTABILITY AND FITNESS FOR A PARTICULAR PURPOSE ARE EXPRESSLY LIMITED IN DURATION TO THE DURATION OF THIS WARRANTY. CRYSTALLINE TECHNOLOGY, INC. AND/OR SELLER DISCLAIMS ANY LIABILITY FOR SPECIAL, INCIDENTAL OR CONSEQUENTIAL DAMAGES.**

Some states/provinces do not allow limitations on how long an implied warranty lasts, or the exclusion or limitation of special, incidental or consequential damages, so these limitations and exclusions may not apply to you. This warranty gives you specific legal rights. You may also have other rights which vary from state/province to state/province.

**This is Crystalline Technology, Inc.'s exclusive written warranty.**

6.2 No Liability for Consequential Damages. TO THE MAXIMUM EXTENT PERMITTED BY APPLICABLE LAW, IN NO EVENT SHALL Crystalline Technology, Inc. ("CTI"), OR ITS SUPPLIERS BE LIABLE FOR ANY SPECIAL, INCIDENTAL, INDIRECT, OR CONSEQUENTIAL DAMAGES WHATSOEVER (INCLUDING, WITHOUT LIMITATION, DAMAGES FOR LOSS OF BUSINESS PROFITS, BUSINESS INTERRUPTION, LOSS OF BUSINESS INFORMATION, OR ANY OTHER PECUNIARY LOSS) ARISING OUT OF THE USE OF OR INABILITY TO USE THE SOFTWARE, EVEN IF Crystalline, Inc. HAS BEEN ADVISED OF THE POSSIBILITY OF SUCH DAMAGES.

**7. MISCELLANEOUS**

The United Nations Convention on Contracts for the International Sale of Goods is specifically disclaimed. If any provision of this LICENSE is inconsistent with, or cannot be fully enforced under, the law, such provision will be construed as limited to the extent necessary to be consistent with and fully enforceable under the law. This agreement is the final, complete and exclusive agreement between the parties relating to the subject matter hereof, and supersedes all prior or contemporaneous understandings and agreements relating to such subject matter, whether oral or written. Customer agrees that it will not ship, transfer or export the SOFTWARE into any country, or use the SOFTWARE in any manner, prohibited by the United States Bureau of Export Administration or any export laws, restrictions or regulations. This LICENSE may only be modified in writing signed by an authorized officer of Crystalline Technology, Inc. ("CTI").

# Quick Start

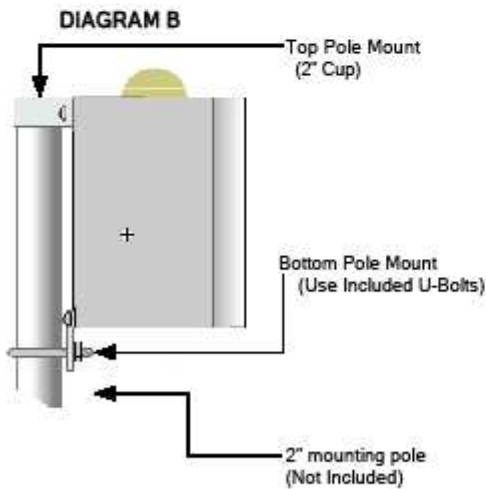
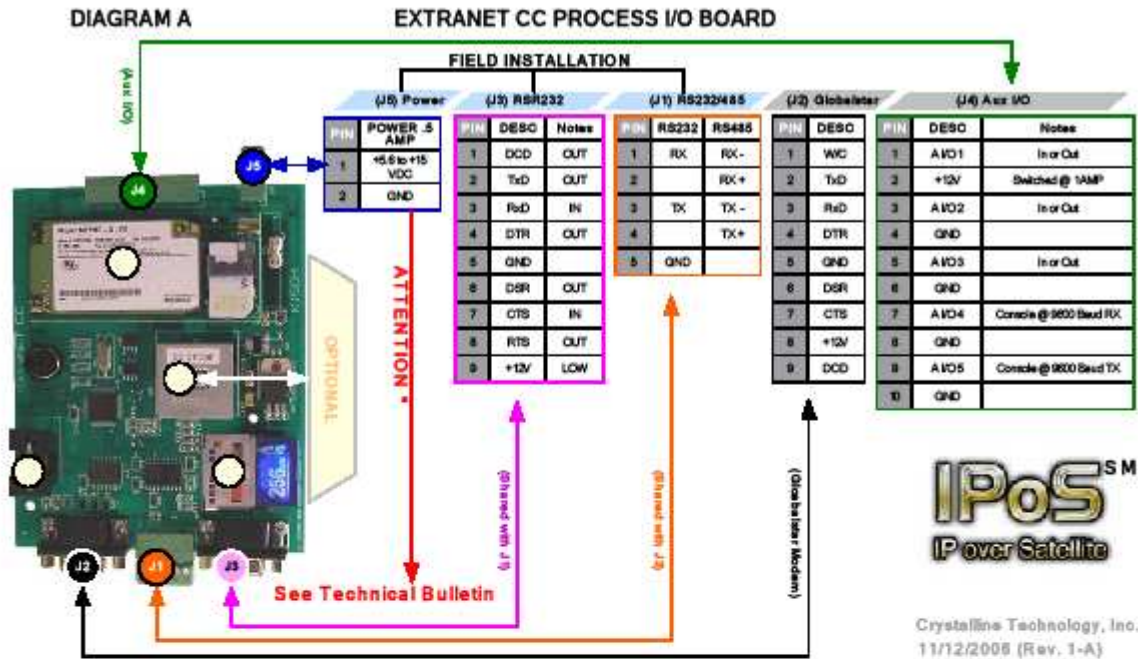

Crystalline Technology, Inc.  
67 N Silicon Suite 150  
Pueblo West, CO 81007  
Phone: 719-543-2577

Email: sales@NearTime.com  
WEB: <http://www.ExtraNETcc.com>

## QUICK START

- Locate the 2" mounting pole where it has a clear view of the sky for both the satellite radio and the solar panel.
- Mount unit at the top of the pole, above any other obstructions.
- Connect the Flow Computer RS232 TX, RX, and Ground wires to the ExtraNET CC connector J1 (See Diagram A)
- Connect power (+9 to +15VDC) to the ExtraNET CC connector J5 (See Diagram A)
- Connect a Lap Top to J4 and use SLOW or Hyper Terminal at 9600 baud, 8 Bits, No Parity
- Press the space bar, you will see a menu.
- Test the communications to the Flow Computer (command "S" for Bristol, command "T" for Fisher)
- Test the communications over the satellite to the host computer with command "P" (Send Poll RBX)

Each ExtraNET CC satellite communication system is provided in housing designed to meet the NEMA Type 4x specifications and to operate in a Class I, Division 2, Groups C & D environment with a nonincendive rating (see Appendix A).

- 1) Locate a suitable site for mounting the ExtraNET CC. Brackets are provided to allow easy mounting to a pipe using user supplied u-bolts.
- 2) Configure the Gas Flow Computer using Group 2, Local 1, and 9600 baud as the communication settings for communications used with the ExtraNET CC.
- 3) A three wire interface is required to the gas flow computer. It is suggested that you use the 5 pin Phoenix connector for field wiring to the gas flow computer.  
J1 Pin 1 to Gas Flow Computer RS232 Transmit  
J1 Pin 3 to Gas Flow Computer RS232 Receive  
J1 Pin 5 to Gas Flow Computer RS232 Ground
- 4) Connect power to the 2 Pin Phoenix connector at J5. The voltage should be between 12 and 15 volts with positive on Pin 1 (closest to 10 pin connector) and ground to Pin 2 (closest to edge of board).
- 5) Connect the diagnostic cable to the 10 pin Phoenix connector J4, the other end to a com port on your computer. Using HyperTerminal set to 9600 baud, 8 bits, 1 stop, no parity you should see a menu when you press the space bar.
- 6) For a Fisher ROC installation you can press the "T" command. You should see a message indicating successful communication to the GFC you are connected to.
- 7) All other settings will be preconfigured at the factory to minimize installation issues.

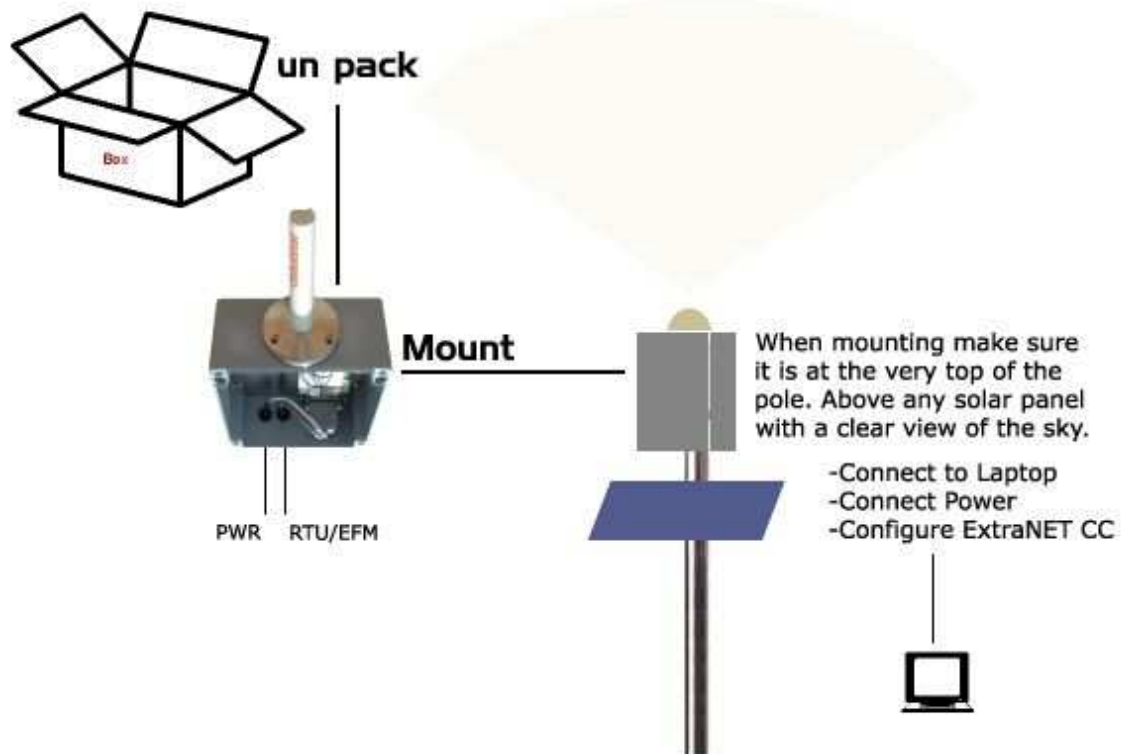

# Introduction to the ExtraNET

## **Features**

ExtraNET CC delivers seamless point to point data communications over a transparent network using satellite and / or a GSM/GPRS, 1X, or CDMA “cellular” modem. ExtraNET CC delivers reliable digital data virtually anywhere in the world using QUALCOMM’s patented CDMA technology and the Globalstar constellation of Low-Earth-Orbit (LEO) satellites. Also supported is an optional GPS for position and velocity data.

ExtraNET CC takes care of the IP network requirements and provides a transparent RS232 or RS485 interface to your equipment. It works with almost any host that supports TCP or UDP over an IP network giving you the complete comfort of managing your own data.

Each ExtraNET CC satellite communication system is provided in housing designed to meet the NEMA Type 4x specifications and to operate in a Class I, Division 2, Groups C & D environment with a nonincendive rating (see Appendix A).

### **ExtraNET CC Features:**

- Approved NEMA 4X fiberglass enclosure provides weather protection in most environments.
- Optional Static IP
  - Allows complete integrated connectivity via a private virtual network (VPN) direct from your host server to the Globalstar Network Operations Center (NOC). Simply send a TCP or UDP packet to a private IP and ExtraNET will establish the connection in approximately 6 seconds. Data can then be sent or received from the remote site with a throughput of 9.6 kbps full duplex.
  - Alternatively the remote device can initiate a connection with your host.
  - Secure access via the Internet can be arranged through a public gateway where a VPN is not desirable or possible (roaming host)
- Default Dynamic IP allows the remote user to access the public internet for host-less applications.
  - SMS messages can be sent to the ExtraNET CC to initiate remote action and or connections back from a Dynamic IP.
- Five configurable I/O points user configured for analog input (0 to 5 VDC) or digital output for remote monitoring and control in standalone applications.
- Optional cellular modems are available for most carriers.
- Optional GPS module supports NMEA 188, TIAP, and TSIA protocols
- Optional local data storage up to 1 GB using removable SD memory
- Activity timers automatically disconnect on user configured “no activity” or “maximum connect time” parameters.
- Always On, always ready operation. Custom low power modes available on request.

## Overview

ExtraNET CC is a universal communication controller supporting the Globalstar™ data modem to allow efficient data communications from virtually anywhere in the world. In addition to satellite support, ExtraNET CC also supports optional modules for GSM/GPRS™, CDMA™, Edge™, and 1 x™ cellular network providing a very flexible platform capable of utilizing existing infrastructure.

ExtraNET CC works with the #777 data service offered by Globalstar and takes care of the PPP negotiations and provides a complete TCP/IP stack. External equipment can be connected to the ExtraNET CC through the RS232/RS485 software selectable interface and communicate at any standard baud rate from 300 to 115,200 baud using a standard 8 bit asynchronous protocol.

ExtraNET CC supports both the Dynamic IP and the Static IP modes of Globalstar. In a Dynamic IP mode, ExtraNET CC will respond to SMS commands and is capable of gathering data from customer equipment and establishing a connection on demand. In the Static IP mode, ExtraNET CC will in addition to the SMS mode, support data on demand by establishing a connection to your host upon reception of any IP traffic.

Other features of ExtraNET CC include optional GPS for location, movement, and/or time specific functions. Five I/O points are provided which can be selectively configured for analog input (10 bit 0 to 5 volts DC) or digital output capable of sourcing 25 mA of power. An additional output is provided which will switch the source 12VDC and provide up to 1 Amp of power for powering external sensors or equipment.

An SD (Secure Digital) socket is provided for data logging applications. SD memory devices with up to 1GB of storage capacity are commonly available and most electronic specialty stores where digital cameras and PDA's are sold.

ExtraNET CC is packaged in a NEMA 4X fiberglass enclosure, resistant to moisture, dust, and corrosion to provide many years of trouble free service.

The result is a very efficient communication solution that works with virtually any host to provide access to remote equipment without the traditional requirements for infrastructure (towers). Economical airtime packages are available to suit virtually any application.



## Connection to External Equipment

ExtraNET supports several interfaces to optional or customer supplied equipment. J4 (top left) is a 10 pin Phoenix™ connector that allows connection to external sensors and controls. The connector is labeled from left to right (1 to 10) and arranged in pairs. Pins 1 & 2 are for IO 1 with pin 1 being signal and pin 2 being ground. Pins 2 & 3 are for IO 2 and so forth to pins 9 & 10 for IO 5 (notice that future versions of ExtraNET will change the definition of pin 2)

Each of the IO points are supported in custom versions of ExtraNET CC and can be defined as analog input or digital output. When configured as an output each point can sink or source up to 25mA at 5 VDC. A 10 bit analog to digital converter is used when configured for analog input. Each IO point is protected against surges and spikes.

J5 (top right) is the power input to the board. A clean power source capable of providing 6 to 16VDC at up to 5.5 Watts of power (for transmit) is required.

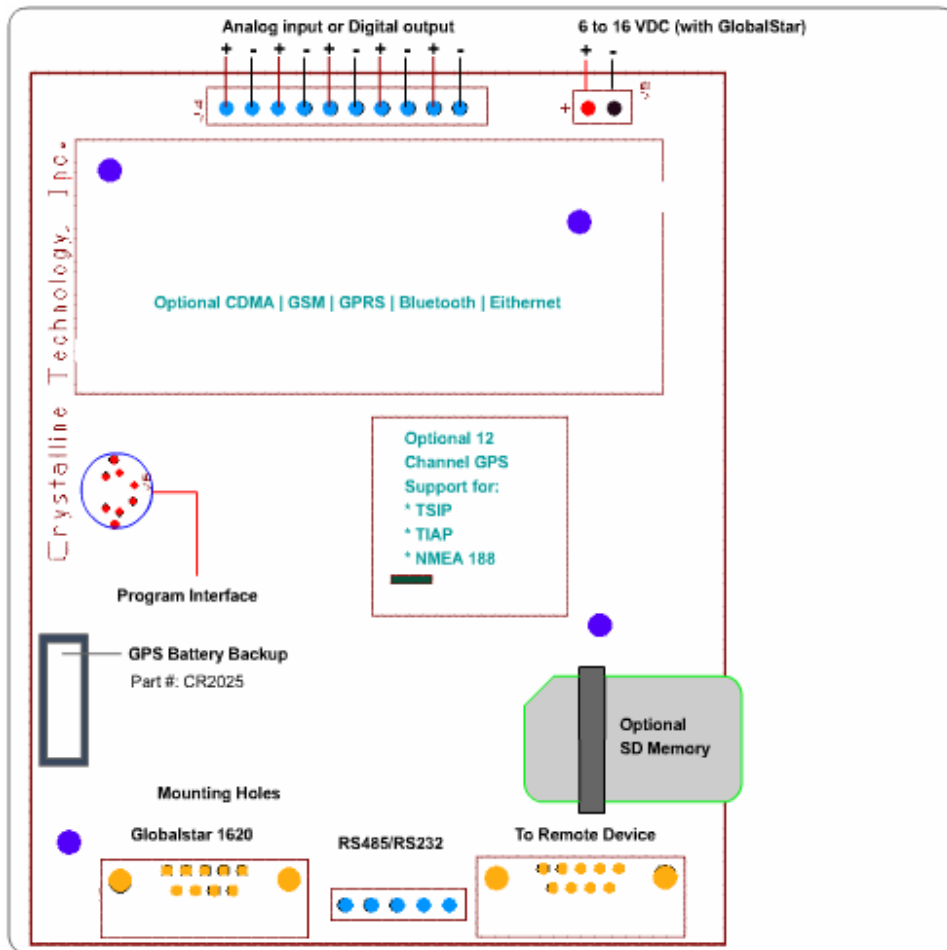

Figure 1 (ExtraNET Diagram)

The Program interface is used for configuration and special diagnostics. A lap top computer or other ASCII terminal can be connected to this port. Please see the section on “Diagnostic Cable” for more information about the required cable and interface for this port.

U7 is for an optional CDMA, GSM/GPRS, Edge, 1X, Bluetooth, or Ethernet module installed in the three vertical connectors located below J4 and J5. Please contact Crystalline Technology, Inc. for more information concerning these modules.

U8 supports an optional high performance 12 Channel GPS that can be used for positional or time critical applications. When the GPS is used then the battery B1 socket should have a lithium CR2025 3 Volt battery installed to reduce GPS startup time.

F1 is a 2Amp slow blow fuse provided to protect the ExtraNET CC from excessive power.

U9 is for applications where large amounts of data need to be retained. A standard SD (Secure Digital) is used with capacities up to 1GB. As an example, in natural gas applications a sample of DP, line pressure, temperature, and flow rate could be logged once per second for over 2 years. Other applications for logging GPS data, audit data, or other special events can be conceived. Please contact Crystalline Technology, Inc. to discuss any application of the SD memory that you might desire.

J1 (center left) is a 5 pin Phoenix™ connector for interfacing to customer supplied equipment. This interface is user selectable during configuration for RS232 or RS485 levels. When configured for RS485 a full duplex 4 wire interface is supported. The ExtraNET CC has a 100 ohm termination resistor on the receive lines.

For RS485:

- Pins 1 and 2 is the receive data (data sent to the ExtraNET CC)
- Pins 3 and 4 are transmit data (data sent from the ExtraNET CC)
- Pin 5 is ground

For RS232:

- Pin 1 is receive data (data sent to the ExtraNET CC)
- Pin 3 is transmit data (data sent from the ExtraNET CC)
- Pin 5 is ground
- (Pins 2 and 4 are not supported when configured as RS232)

J2 (top left) is designed to support the Globalstar 1620 modem. This cable is normally included as part of an ExtraNET CC package.

**(J2 Interface Cable to Globalstar 1620 modem)**

DB-9 M	DB-25F	Description
ExtraNET CC	1620 Modem	
Pin 2	Pin 2	TX Data
Pin 3	Pin 3	RX Data
Pin 4	Pin 4 & Pin 20	DTR
Pin 5	Pin 7	Ground
Pin 6	Pin 6	DSR
Pin 7	Pin 5	CTS
Pin 8	Pin 9 & Pin 10	+12 VDC Power
Pin 9	Pin 8	DCD

J3 (bottom left) is shared with J1 and is the RS232 interface to customer equipment. The function of J3 is shared with the 5 pin Phoenix connector labeled J1 (middle left). Please reference the table below for pin definitions of the DB9F J3 connector. This connector does not strictly conform to RS-232 standards and caution is recommended to avoid damage to the ExtraNET CC. This connector shares function with J1 and is only valid when ExtraNET CC is configured for RS-232. When RS-485 is selected you should use J1 and leave J3 disconnected:

**(J3 Interface - RS232 Customer Interface)**

Pin 1	DCD Output (0 to 5 Volts)
Pin 2	TX Data (RS-232)
Pin 3	RX Data (RS-232)
Pin 4	DTR Output (0 to 5 Volts)
Pin 5	Ground
Pin 6	DSR Output (0 to 5 Volts)
Pin 7	RTS Output (RS-232)
Pin 8	CTS Input (RS-232)
Pin 9	+8 Volts (Very Low Power)

## Diagnostic Cable

After completing the mounting and wiring of the ExtraNET CC installation you should connect to the unit with a lap-top computer or other suitable terminal to complete the configuration. Diagnostics are supported by connecting a terminal or computer to the 10 pin I/O connector of the ExtraNET CC. The I/O is restricted to signal levels of 0 to 5 VDC and do not strictly conform to RS232 standards when using the 10 pin I/O connector. A cable is provided that will handle the interface requirements with a DTE device such as a lap top computer running the HyperTerminal program.

It is very important that you use this special cable with the approved interface since the diagnostic port on the ExtraNET CC is not RS232 and is not protected from improper use. Permanent and un-repairable damage will result if proper cables are not used.

Figure 2 (diagnostic cable)

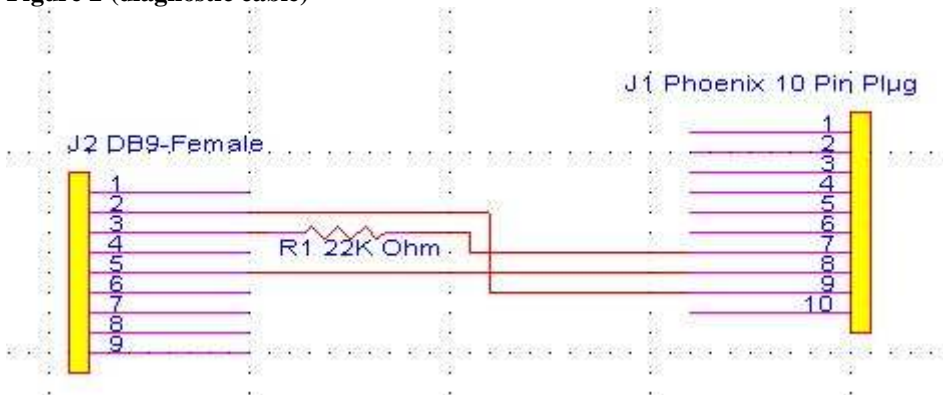

You are now ready to perform the final steps of the installation. Using HyperTerminal or some other suitable terminal emulation program select the following settings:

<b>Baud Rate:</b>	<b>9600</b>
<b>Data Bits:</b>	<b>8</b>
<b>Stop Bits:</b>	<b>2</b>
<b>Parity:</b>	<b>None</b>
<b>Handshake:</b>	<b>None</b>

## Configuration

Upon connection to the ExtraNET CC you may enter a space (single press of the space bar) and a menu of commands will be presented. Only after completely understanding the commands should you attempt to make any changes in the configuration of the ExtraNET CC. It is quite easy to end up with a device that doesn't work simply because the configuration is incorrect for the application required. The following menu is representative. The menu will actually provide different options depending on the configuration that it is currently using. Using this interface you can change the way that the unit works.

*NOTICE: The Globalstar 1620 data modem can be configured for baud rates ranging from 9600 baud to 115200 baud. Since the over the air rate is 9600 baud there are some considerations that are made for buffering data. As an example, when ever possible the 1620 should be configured for the same data rate as the customer equipment connected to J1 or J3. Although the I/O of the ExtraNET CC is interrupt driven with buffers for data, there are opportunities where possible data overruns could occur if you are trying to send more data than can be buffered.*

### Configuration Menu

ExtraNET CC

(c) 2005,2006 by Crystalline Technology, Inc

See <http://www.ExtraNETCC.com> for more information.

Compiled 05-Jan-06 08:57:44 Serial# 000003f4

- D) Display Settings
- C) Connect to Globalstar gateway
- H) Hangup Globalstar Modem
- M) Configure SMTP
- E) Send E-Mail
- B) Reset ExtraNET CC
- F) Configure ExtraNET CC Mode
- G) Configure Globalstar Modem
- W) Configure Wireless Modem
- R) Show Communication Status

Each of these commands are simple 1 character commands. These commands should be used when no sessions to the Globalstar or optional modems are in progress.

#### D) Display Settings

The display settings command will show a synopsis of the various settings in the ExtraNET CC. It is a good idea to issue the "D" command after going through the

configuration of the “F” command. The “D” will display several different items. Below is an example of the information displayed in the “D” command.

```
Not connected
Configured for FixedIP Service
UDP receive port 2101 open
UDP send to port 2101 at 10.202.0.35
Will check for SMS messages
Will hangup on TCP close
No activity timeout: 5
Maximum Connect Time: 300
Terminal baud rate: 9600
Terminal port configured for RS232
socket 0: port=0, State=TCP_CLOSED
socket 1: port=0, State=TCP_CLOSED
socket 2: port=0, State=TCP_CLOSED
```

### ***L) List Event Log***

The ExtraNET CC is capable of logging the previous 100 connectivity and initialization events. This is a very useful feature particularly if you need to know when there is satellite coverage available. The event log will tell you when coverage became available and how long your unit was in a coverage area. All times listed in the event log are UTC. The correct time will be acquired from the satellite or cellular system. Any event with a date and time of 0/00/00 0:00:00 indicates that the correct time was not acquired when that even was logged. The even log can be cleared by selecting the “Clear event log?” option in the “Configure ExtraNET CC Mode” (“F”) command.

### ***C) Connect to Globalstar gateway***

The “C” command is used to initiate a PPP session with the Globalstar #777 internet service. This command is primarily used in testing before we ship the product to ensure that the modem is activated and that the antenna and cabling function properly. Keep in mind that issuing the “C” command does use airtime on the satellite network as it fully establishes 2 way communication between ExtraNET CC and the Globalstar network. There may be circumstances in which the end user may want to use the “C” command, but it is generally used for testing and diagnostic purposes.

### ***H) Hangup Globalstar Modem***

The “H” command is used to force the modem to disconnect if a connection is active and go through a complete reset. This is also a command which is primarily used for testing and diagnostic purposes. The end user will rarely need to use this command.

## ***B) Reset ExtraNET CC***

The “B” command is used to perform a graceful reset of the ExtraNET CC. This command will gracefully disconnect the 1620 from the Globalstar network and cause the ExtraNET CC board to re-initialize the 1620. This will also ensure that all user selectable parameters are loaded properly. It is strongly recommended to issue the “B” command after changing any configuration in the “F” command.

## ***G) Configure Globalstar Modem***

The “G” command is used to open a terminal connection to the Globalstar modem. This allows the user to issue AT commands to the Globalstar 1620 modem. This command is also used primarily for testing, but can also be very beneficial to the end user. The “G” command simply opens a terminal that allows you to issue any compatible AT command to the modem for a multitude of different functions. NOTE: While in the Globalstar 1620 Terminal the ExtraNET CC is unable to accept any incoming connections. It is important to note that the terminal will automatically close after 120 seconds to prevent the ExtraNET CC from being locked into an unusable state for remote terminated data applications.

## ***R) Show Communication Status***

The “R” command is capable of displaying several different types of information. When issued, you will see the status of the Globalstar modem. If there is no 1620 attached to the ExtraNET CC you will simply see “Globalstar not ready.” If a 1620 is connected and there is coverage available, you will see “Globalstar online.” If your unit is configured to use cellular, you will see its status here as well. When the “R” command is issued, ExtraNET CC also sends “at\$qcstatus” to the 1620 and returns the result to you. This is a very fast way to determine if you currently have satellite coverage. It also saves you from having to enter the Globalstar terminal to manually input the command.

## ***S) Test BSAP Connection***

This command is only used in S.C.A.D.A. (supervisory control and data acquisition) applications. The “S” command will test communication between the ExtraNET CC and a Bristol Babcock™ flow computer. It is advisable to issue this command after initial installation if your configuration uses the BSAP™ protocol. This will ensure that communication is taking place between your equipment and the ExtraNET CC.

## ***T) Test ROC Connection***

This command is also used only in S.C.A.D.A. applications. The “S” command will test communication between the ExtraNET CC and a Fisher<sup>TM</sup> flow computer. It is advisable to issue this command after initial installation if your configuration uses the ROC<sup>TM</sup> protocol. This will ensure that communication is taking place between your equipment and the ExtraNET CC.

## ***F) Configure ExtraNET CC Mode***

Upon entry you will be presented with a series of questions. Some of the questions will include the current setting that is in effect for that question.

### **Fixed IP Service? (Y)**

Are you using the Static IP mode offered by Globalstar? The Static IP mode requires a VPN connection to the Globalstar NOC (Network Operations Center) and modems that have been specially provisioned for service with a Static IP. ExtraNET CC will answer inbound requests to establish a data session with the network if you answer Y for yes. If you answer N then the ExtraNET CC will check for SMS messages about once per second and respond appropriately as required.

### **Check for SMS messages? (N)**

Even configured as a Static IP node there are opportunities where the SMS message still has value. As an example, if you are located deep in a canyon that has limited view of the sky; you may not have continuous coverage by the Low Earth Orbiting (LEO) satellites operated by Globalstar. In these cases a host may wish to send a SMS message to a remote node. Globalstar will queue this SMS message until it gets the destined node registered on the satellite. Thus as soon as a satellite goes over head (typically in only a few minutes) the ExtraNET CC will receive the SMS message and initiate the connection back to the host. This will reduce possible errors on the host induced by polling a remote unit that is not within satellite coverage at that time.

### **Configure as Internet/Intranet switch? (N)**

In some applications ExtraNET CC can be used to provide Internet or Intranet service based upon the availability of a signal from a cellular site using an optional GSM/GPRS or CDMA interface. Since connection through these services is typically lower cost than through the satellite ExtraNET CC will use them where possible. If the service drops out or is not available then ExtraNET CC will automatically switch to the Globalstar network thus providing service virtually anywhere in a mobile environment.

### **MAC address 0x00-0x00-0x00-0x00-0x00-0x02 Change? (N)**

Generally not used, the MAC address can be configured with a unique number on the network when enhanced security is required by your network administrator. If you enter a Y for yes then you will be prompted for each of the 6 octets of information.

### **Configure UDP Port? (Y)**

ExtraNET CC supports the UDP (User Data Protocol) for efficient communication to remote equipment where a high level protocol is used such as BSAP, MODBUS, ROC, and many others. Although UDP does not have any error checking built in with retries, the application protocol being transported generally does. Unlike TCP, the UDP protocol is considered connectionless. You simply send a packet to the remote node blindly. If the remote node receives the packet and is supposed to respond then it will do so in a like fashion. This is analogous to standard data radio service where you transmit to a remote node and if it receives and is program to respond it will do so.

### **UDP Port to use on ExtraNET CC (2101)**

We suggest port 2101 used by our API (Application Program Interface). Any port from 1 to 65535 may be used.

### **IP Address of Remote Machine is 10.202.0.35, Enter New Address:**

**BYTE0: 10**

**BYTE1: 202**

**BYTE2: 0**

**BYTE3: 35**

Since UDP is a “connectionless” protocol, ExtraNET CC needs to know what the IP address is of the machine that will be receiving the data from the ExtraNET CC. This should be a network address that is available to the unit when ever connected. A dynamic IP on the host computer is not currently supported. You must enter the complete IP address one octet (byte) at a time as shown above.

### **Port to send UDP data to on Remote Machine (2101)**

This is the UDP port on the host that data will be sent to. Again, 2101 is suggested and used in the example programs included.

### **Maximum amount of NO ACTIVITY time (10 seconds) before disconnecting satellite?**

A timer is started as soon as connection is established to the Globalstar network. The no activity timer (seconds) is reset anytime data is sent or received over the network. If the timer expires before being reset then the connection will be broken and ExtraNET CC will disconnect from the network to eliminate “dead airtime”. You should allow at least 2 seconds for any outstanding packet to be transmitted.

### **Absolute maximum time allowed for connection? (15)**

A second timer is started in a similar fashion but cannot be reset. If the connection exceeds this time (measured in seconds) then ExtraNET CC will disconnect from the satellite. You should allow enough time to perform any communications that you might want to do. You want this to disconnect only if something has gone terribly wrong and a unit is just sending data non stop or has some other failure. This time is measured in seconds.

### **Minimum signal from GSM/GPRS or CDMA before selecting Satellite (-95)?**

This question really only has meaning if you have configured the unit for Internet or Intranet service above. The number represents a RSI (received signal indicator) and although negative should be entered without the minus “-“ sign. The lower the number, the stronger the signal required by the GSM/GPRS or CDMA modem before switching to the Globalstar satellite network.

### **Baud Rate for local Terminal / RTU (19200)?**

This is the baud rate that is used to communicate with the customer supplied equipment (or a computer if using the Internet / Intranet mode). Any standard baud rate from 300 to 115200 baud can be used but if you want 115200 baud you must enter 11520 and leave off the last zero. This is due to the way ExtraNET CC stores the number in a 16 bit register that only goes to 65535. Standard baud rates supported are: 300, 600, 1200, 2400, 4800, 9600, 19200, 38400, 57600, and 115200 baud. This is the baud rate used to communicate with the customer equipment, not the actual baud rate used over the satellite or the cellular system.

### **Use RS232 (Y) or RS485 (N)? (Y)**

Finally you can select the levels used to communicate with the customer equipment. RS232 is available on the DB9 connector while both RS232 and RS485 are available on the 5 pin phoenix connector provided. Refer to the wiring diagrams for more information on connecting customer equipment.

## ***G) Configure Globalstar Modem***

Provided for direct access to the Globalstar 1620 data port on the modem. Any of the recognized “AT” commands may be executed. While in this mode ExtraNET CC will not recognize any normal data connects to the Globalstar gateway and will not negotiate the PPP session. It is important that you properly exit this mode or you will render the ExtraNET CC non-functional for normal applications. To exit this mode you must enter “QUIT” all in upper case.

This function is sometimes useful to determine what gateway you are currently registered with on the Globalstar network. As an example you can enter the AT\$QCSTATUS as shown below:

```
GlobalStar 1620 Terminal ('QUIT' to exit)
at$qcstatus
SERVICE AVAILABLE: YES
SERVICE MODE: GLOBALSTAR
PROVIDER: GSTAR USA
GATEWAY: 1
RSSI: 4
REGISTRATION: YES
ROAMING: NO
CALL STATE: IDLE
CALL TYPE:
CALL DURATION: 0
NUMBER:
```

OK

In this example we have service available and are registered on the satellite using gateway 1 with a RSSI of 4 (out of 4). This information is useful in determining availability of service. You should always try to get the best possible view of the sky when determining the mounting location of the ExtraNET CC. Since the Globalstar network consists of a number of low-earth-orbiting (LEO) satellite it is likely that if you wait a few minutes a satellite will pass over head somewhere in the open sky that you can see.

Again, it is important that you properly exit from this option so ExtraNET CC can resume its normal mode of operation. When you enter the “QUIT” (case sensitive) you will see the menu reappear upon exit. You will not see the “QUIT” echoed back to your terminal.

### ***W) Configure Wireless Modem***

This option is not available on units not equipped with the wireless modem. If you have an optional modem plugged into the socket at U7 then you may send commands to the modem in the same fashion as was used for the Globalstar modem above. The same rules apply, you MUST exit the W option with the “QUIT” all in upper case.

Each version of the socket modem has a unique set of commands that are supported. Normally the socket modem will be preconfigured to meet your application requirements and this mode is not needed for any other configuration of the modem.

## **R) Show Communication Status**

The “R” command is capable of displaying several different types of information. When issued, you will see the status of the Globalstar modem. If there is no 1620 attached to the ExtraNET CC you will simply see “Globalstar not ready.” If a 1620 is connected and there is coverage available, you will see “Globalstar online.” If your unit is configured to use cellular, you will see its status here as well. When the “R” command is issued, ExtraNET CC also sends “AT\$QCSTATUS” to the 1620 and returns the result to you. This is a very fast way to determine if you currently have satellite coverage. It also saves you from having to enter the Globalstar terminal to manually input the command.

**SERVICE AVAILABLE: YES**  
**SERVICE MODE: GLOBALSTAR**  
**PROVIDER: GSTAR USA**  
**GATEWAY: 1**  
**RSSI: 3**  
**REGISTRATION: YES**  
**ROAMING: NO**  
**CALL STATE: IDLE**  
**CALL TYPE:**  
**CALL DURATION: 18**  
**NUMBER: #777**

**OK**

**Globalstar Online**

In the example above, the unit has service available, is operating in the Globalstar service mode and has service provided by GSTAR USA. Service is currently being provided from Gateway 1 (Clifton, TX) and has a receive signal strength indicator (RSSI) of 3 (scaled from a poor signal of 0 to a very good signal at 4). The unit is currently registered and not roaming. The Call Duration is the total length of the last data session. For ExtraNET all connects are made through the #777 data services and enjoy the special airtime rates offered by Globalstar.

## Using ExtraNET CC for SCADA Applications

In order to contain costs, ExtraNET CC is only connected to the Globalstar network using airtime when it is necessary to send or receive data between an user supplied RTU (Remote Terminal Unit) and a SCADA (Supervisory Control and Data Acquisition) host. Some RTU's can automatically send data to a host when necessary but in most cases it is the SCADA host that "polls" the RTU for data.

It is necessary to develop a method of initially establishing the connection through the Globalstar network to your RTU. When using Globalstar's Static IP mode, your host is connected directly to the Globalstar NOC (Network Operations Center) using a VPN (Virtual Private Network). Any time that the NOC receives an IP packet (UDP, TCP, or ICMP) with an IP address matching an ExtraNET CC node on your network, a session request is made by the NOC to the ExtraNET CC. This process takes a few seconds (typically 6 to 8 seconds) to accomplish. Once the ExtraNET CC has completed the PPP (Point – to – Point Protocol) negotiations a single UDP packet on port 3000 will be transmitted to the host with the message "CONNECT 9600" indicating to the host that the node is online and ready to send and receive data.

Another approach is to send a SMS (Short Message Service) message to the ExtraNET CC node when you want to establish a connection. This has some potential advantages if the node is not in a good location that has coverage all the time or if the node is not continuously powered up and ready to receive data. Globalstar's network will actually queue the SMS message until it has the destined node registered on a satellite. Once the SMS message is received by the ExtraNET CC it will immediately (within about 1 to 2 seconds) try to establish data connection to the Globalstar network. Upon negotiation of the PPP session ExtraNET CC will send a UDP packet to port 3000 on the host with the message "xx.xx.xx.xx is online" where the xx.xx.xx.xx will contain the actual IP address provided to the ExtraNET CC by the Globalstar network.

For normal Dynamic IP modes of operation on the Globalstar network the SMS message is the only way for a host to initiate a data session. Further, since the dynamic IP assigned by Globalstar is on a private network and is not accessible from the public Internet, it is necessary for the ExtraNET CC to establish a TCP session with the host (and not the other way around).

For most SCADA applications it is suggested that you utilize UDP (User Datagram Protocol) over IP (Internet Protocol) sometimes referred to as UDP/IP. UDP is a connectionless protocol that is typically used to broadcast data to a node or group of nodes. In SCADA applications it allows data to be sent efficiently to a node where other protocols such as TCP (Transmission Control Protocol) is a connected protocol that requires that each packet transmitted be checked for errors and either acknowledged or retransmitted.

Since most protocols such as BSAP (Bristol Serial Asynchronous Protocol), MODBUS, ROC (Emerson/Fisher/Rosemont) and other common SCADA application protocols have built in error detection and retries, using the TCP protocol simply adds overhead and reduces overall efficiency.

Through clever use of the UDP protocol it is possible to “optimize” the performance over an IP network. As an example, if you transmit a “packet” of user protocol (BSAP, MODBUS, ROC, etc.) and send it as a single UDP packet over the network then you reduce the amount of packets that have to be reassembled on the other end before a RTU can respond. Sometimes you can simply adjust your UDP packet size to improve performance but we have found that knowing a little bit about the user application protocol can result in greatly improved performance.

Crystalline Technology, Inc. has developed a simple “API” (Application Programmer Interface) that actually performs a very basic parsing of a BSAP message. The API determines the BSAP group and node address that data is being sent to and the length of the message.

Given a quick database or local table in memory one could look this group and local address up and map it to the IP address of the ExtraNET CC that the data is to be sent to. It is then a simple matter to send a single packet of the proper size to the RTU in the field very efficiently.

There are additional capabilities that could be exploited for applications that use SCADA hosts such as OpenBSI for a Bristol Babcock RTU. One might have an interface program automatically establish the session with an ExtraNET CC node at a scheduled time and send it an SMS message. Upon receipt of the “xx.xx.xx.xx is online” message the interface program could set a bit in a database table that informs “Harvester” to collect the required data NOW. Each packet sent by the host would be packetized for optimum performance using UDP.

The sample VB.NET program contains an example of how to implement such a scheme. Crystalline Technology, Inc. can provide a complete application meeting your specific requirements for a fee.

The ExtraNET CC uses a slightly different method of determining packet size of the returned data. In order to support the greatest number of protocols, ExtraNET CC will wait 3 character times or 3mS whichever is greater before determining that the RTU is finished sending data. It then takes this data and sends it to the host in a single packet. If there is no TCP session open the data will be sent using a UDP packet.

A maximum packet size of 900 bytes is supported by ExtraNET CC.

The UDP port 3000 is defined as a “control port” with special functions. It is suggested that you support port 3000 on your host to send and receive control data. ExtraNET CC will send a message to this port any time a connection has been established. In addition,

once established you can send an arbitrary message to the ExtraNET CC and it will echo it back to you as verification that everything is working correctly. This is similar to a Ping which is also supported by ExtraNET CC.

There are special messages that can be sent to the ExtraNET CC that allow remote configuration of the ExtraNET CC. Please do not use these commands unless instructed by Crystalline Technology as you can render a node useless until somebody physically visits the location and corrects the configuration. For informational purposes only and so that you will not accidentally enter these commands expecting an echo, the following are supported:

WRITE CONFIG  
READ CONFIG  
RESET NOW

The UDP port used for data when sending or receiving information can be set to any port from 1 to 65535 (except for 3000). We suggest port 2101 if you want to use our example VB.NET programs.

TCP is an alternative way of sending or receiving data between a SCADA host and the RTU in the field connected to the ExtraNET CC. Although not always as efficient as UDP for most applications, it is directly supported by many SCADA hosts that work with “Terminal Servers” and may not require any additional software. TCP port 23 is supported by ExtraNET CC.

### ***Modbus/IP***

Modbus/IP is a well documented implementation of MODBUS encapsulated in a TCP packet. By standard convention port 502 is assigned to handle the Modbus encapsulated data. ExtraNET will extract the data from the TCP packet and present it to the customer’s equipment in the standard legacy Modbus RTU protocol.

The process involves analyzing each packet received on port 502 and to process the 6 byte header. ExtraNET CC then computes the proper CRC for the remaining data and sends the data to the customer computer.

Each packet received from the customer device is first verified with the CRC. Upon success the 6 byte header required for Modbus/IP is constructed and the data is sent back to the SCADA host on the same TCP connection.

Because of the translation between Modbus/IP and traditional Modbus RTU the message there is a limitation of 240 bytes in the Modbus message. Attempts to do more data will have unexpected results.

## VB.NET sample program

Crystalline Technology, Inc. has developed a simple VB.NET program that is useful for testing and understanding the functions and capabilities of ExtraNET CC. This program was written using “Microsoft Visual Studio .NET 2003”™ for use on a Windows™ platform that supports “Framework”. Source is provided and it should be easy to port to other platforms such as UNIX if required.

Since the Microsoft included system.web.mail reference does not support e-mail systems other than Microsoft’s we opted to use a more open program “OpenSMTP” available under GNU at [sourceforge.net/projects/opensmtp-net](http://sourceforge.net/projects/opensmtp-net). A copy of the binary is included and you must add a reference to OpenSMTP.dll using Visual Studio before the program can be compiled.

Also included as part of the sample program is a com port driver developed by Corrado Cavalli at [www.codeworks.it/net/index.htm](http://www.codeworks.it/net/index.htm). We made some “minor” tweaks to his program to properly handle events in a method easily understood. This is the class that allows RS232 communications to your host.

The ExtraNETapi.vb has some functions that are useful for sending and receiving UDP messages with the ExtraNET CC.

BSAP.vb has a simple parser to return the length, group, and local address of each BSAP message. Both BSAP and Extended BSAP are supported. Since it is assumed that this program would be directly connected to the host, errors would be unlikely and if there were any errors, the OpenBSI would detect and retry. This eliminated the need to complete parse the BSAP message and to perform the CRC validation.

SMSsend.vb uses the OpenSMTP from above and sends a message to the Globalstar gateway. Globalstar supports an SMTP server that accepts messages when addressed to a proper node and sends them as a SMS message. To send a SMS message to a Globalstar node you simply send a message to [phonenumber@msg.globalstarusa.com](mailto:phonenumber@msg.globalstarusa.com). The contents of the SMS should be limited to a very few character (less than 35) and placed on the subject line. Since this is an open gateway, ExtraNET CC will only respond to the SMS message “CALL HOST”.

Please feel free to contact Crystalline Technology, Inc. if you have any questions.

## ExtraNET Avalanche



### **Overview:**

Avalanche acquires data from a RTU and sends it to the customer in the form of an email. This is useful in applications which log data at pre-determined intervals and report back to a host periodically. This addresses many of the common coverage problems that can be encountered with a LEO satellite constellation and can be particularly useful in areas with a limited view of the sky. Arranging a transmission to take place when you have data can significantly reduce airtime costs incurred due to incomplete connection attempts and the robustness of the Avalanche when actually sending the data. It eliminates the need for a host system to continually retry a data connection if satellite coverage is not available at the remote site during the connection attempt.

### **Features:**

- On-site storage of data
- Fully customizable scheduled polling and reporting
- Can be polled remotely using free SMS messages
- Security available for SMS messages
- Data can be delivered to any email address as an attachment in either binary format or as a convenient comma delimited CSV file.
- With scheduled reporting, the modem can be put to sleep between connections to save power.
- Support for industry standard GFM protocols such as Modbus, Enron Modbus and the Fisher ROC.
- Special advanced features when used with Emerson / Fisher FloBoss
- Support for MODBUS RTU protocol
- Pollable and remotely configurable
- RS232 or RS485 Interface to RTU
- Online data available at <http://www.MeterStar.com>
- Optionally available with restricted access through the use of a VPN direct to Globalstar
- Menu driven configuration system using a simple ASCII terminal
- Special airtime plans may apply

## ***Theory of Operation***

Avalanche is built around the ExtraNET CC platform. This platform includes the management of the QUALCOMM GSP-1620 or GSP-1720 modem. This integration includes power control over the modem, SMS messages, and satellite status among other features.

When Avalanche is initially powered on it will first try to determine the current time. This requires that a Globalstar satellite capable of transmitting on the S band be overhead. You may also access the menu and perform configuration and maintenance using the diagnostic cable at this time. It will stay awake for approximately 3 minutes after it obtains the time while checking the satellite for any over the air configuration changes.

If you have turn on the “Check for SMS messages” then the unit will stay awake indefinitely. Every 10 seconds it checks to see if there are any new commands that have been sent via SMS. SMS messages are unique in the way they are handled in the Globalstar network. When you send a SMS message, Globalstar first looks to see if the unit is registered on any of the gateways. If it is, the message is sent immediately. If the message is not successful for any reason, Globalstar goes through a retry algorithm until the unit does register and the message is sent successfully.

Because SMS messages can be sent by anybody using the Globalstar web site, you can turn on the Advantage “SMS Security”. When the security is turned on, Advantage requires a special key to be sent with each SMS message. The key is unique for every device and changes frequently. In addition to the security, there is a very limited set of commands which must be in exactly the proper form before anything will happen on Advantage.

If you have configured the unit to NOT check for SMS messages then Avalanche will go into a very low power mode requiring only about 10 mA to operate. In the low power mode only the time of day clock and scheduler are left operational. Every 10 seconds the scheduler will check to see if it is time to poll the RTU.

Three different protocols are supported, MODBUS, ENRON Modbus, and the Fisher ROC protocol. In the MODBUS mode you must configure Avalanche with up to 20 different RTU MODBUS addresses, each capable of polling up to 20 different 32 bit IEEE 754 floating point registers. Each entry allows for a different interval to be used.

A typical application might be to read daily records once per day, hourly records once per hour, and perhaps plunger records once every minute. For each poll, Avalanche timestamps the data and keeps it in non-volatile memory.

ENRON Modbus is a derivative of MODBUS that defines certain registers that can be read as lists of data items. This is done to support the API 21.1 requirement for hourly and daily logs (and others). Each manufacture of devices that are sold as ENRON

Modbus may actually define a different number of items to be returned and what these items are when the special registers are read. Please check with Crystalline Technology to determine if the RTU you desire to use with Avalanche is supported. Currently we support ENRON Modbus as delivered by Barton™ and Control Microsystems Incorporated™.

If the Fisher ROC protocol is selected, Avalanche gathers data in accordance to the API 21.1 guidelines for custody transfer. Avalanche reads the first 12 columns of the Daily and Hourly archives, 4 columns from the extended archive, current values for all of the logged registers, the 42 configuration parameters, and the event log. The configuration and events are only sent if they are new.

In addition, the FloBoss is monitored for any RBX originated messages. Upon reception, Avalanche will immediately poll the FloBoss for all the data and send the results to the specified host.

The scheduler is defined during the setup process. You have the ability of sending the acquired data at any interval or at preset times. We strongly suggest at least one report be sent shortly after contract hour. Additional reports can be sent to meet operational requirements.

For FloBoss and most MODBUS applications, the data can be sent to the host very quickly, requiring only about 15 seconds of airtime. We offer service plans designed to fit your reporting requirements.

Data is sent to the host as a file attachment in an email. This attachment can be either a binary file or a CSV file. Note, only the CSV file contains all the data required to meet stringent API 21.1 requirements. Because of the overhead in maintaining the connection to the server, there is not a significant difference in cost in airtime between the two different formats. The binary file is maintained for legacy systems or special MODBUS applications only.

The SMTP server can be the customers, Globalstar's, or one at Crystalline Technology. Because the time required to work the email server is charged against the Globalstar air time, it is important to have a fast server. For additional security, Avalanche can be provisioned for use on a private subnet. These networks are restricted to prohibit outside access and require a VPN (Virtual Private Network) connection direct to a Globalstar gateway.

Avalanche is a complete TCP/IP node on the network. There is no database or processing of the data on the network. All traffic is routed using traditional "internet" techniques and not "massaged" in any way by any system along the way. This provides a high degree of data integrity.

For users who would like the benefit of a complete turn-key system, data can be directed to [www.MeterStar.com](http://www.MeterStar.com).

## Getting Ready to use Avalanche

Avalanche utilizes the Globalstar Low Earth Orbit (LEO) satellite constellation. Since the satellites are in constant motion they will provide coverage where other communications may fail. Even still, to obtain the best possible coverage, you should select a site that has a clear and unobstructed view of the sky.

### ***Installation Considerations***

- With heavy foliage you may need to move away from the foliage, remove some foliage, or try to get above the foliage. Avalanche works with a limited view of the sky but a better view will result quicker acquisition and thus lower power requirements.
- There should be no other equipment blocking any part of the sky including the mast it is mounted on.
- Avalanche contains mounting hardware suitable for a 2" to 2 ½" conduit mast. The mast should be firmly supported to withstand wind, rain, snow, and ice storms which might occur in your area.
- If Solar Panels are used, they should be located BELOW the Avalanche to avoid obstructing the view of the sky.
- Avalanche is rated for service in Class 1, Division 1 locations. The appropriate wiring techniques must be employed to avoid compromising this rating. ***Please see Appendix A.***
- The specification for RS-232 calls for a maximum distance of 50 feet at 20Kbps and the RS-422/485 specification calls for a maximum of 5000 feet at 9600Bps. Data rates are a function of the distance of the cable. The shorter the cable length the higher the data rate that one can achieve. A high quality shielded cable should be used.

### ***Interfacing RTU***

J1 (center left) is a 5 pin Phoenix™ connector for interfacing to customer supplied equipment. This interface is user selectable during configuration for RS232 or RS485 levels. When configured for RS485 a full duplex 4 wire interface is supported. The ExtraNET CC has a 100 ohm termination resistor on the receive lines.

For RS485:

- Pins 1 and 2 is the receive data (data sent to the ExtraNET CC)
- Pins 3 and 4 are transmit data (data sent from the ExtraNET CC)
- Pin 5 is ground

For RS232:

- Pin 1 is receive data (data sent to the ExtraNET CC)
- Pin 3 is transmit data (data sent from the ExtraNET CC)

Pin 5 is ground  
(Pins 2 and 4 are not supported when configured as RS232)

J3 (bottom left) is shared with J1 and is the RS232 interface to customer equipment. The function of J3 is shared with the 5 pin Phoenix connector labeled J1 (middle left). Please reference the table below for pin definitions of the DB9F J3 connector. This connector does not strictly conform to RS-232 standards and caution is recommended to avoid damage to the ExtraNET CC. This connector shares function with J1 and is only valid when ExtraNET CC is configured for RS-232. When RS-485 is selected you should use J1 and leave J3 disconnected:

**(J3 Interface - RS232 Customer Interface)**

Pin 1	DCD Output (0 to 5 Volts)
Pin 2	TX Data (RS-232)
Pin 3	RX Data (RS-232)
Pin 4	DTR Output (0 to 5 Volts)
Pin 5	Ground
Pin 6	DSR Output (0 to 5 Volts)
Pin 7	CTS Output (RS-232)
Pin 8	RTS Input (RS-232)
Pin 9	+8 Volts (Very Low Power)

## Avalanche Menu and Configuration

You need an ASCII terminal such as a Laptop running terminal software like Windows, Hyper Terminal or SIOW. Using the diagnostic cable, connect the green 10 pin phoenix connector to the processor board and the DB9-F connector to your computer's serial port. Connect to the unit at 9600 baud, 8 bits no parity and press the spacebar.

SIOW is a program that provides a terminal interface that is quick and easy to use. You can download the program from our web site at:

<http://www.Crystalline.us/downloads/ExtraNET/siow.zip>

Upon power up, reset, or pressing the space bar, you will be presented with the following display and menu. The Build number is unique to the version of the program loaded in to the device.

```
ExtraNET SF Avalanche
(c) 2005, 2006, & 2007 by Crystalline Technology, Inc
See http://www.ExtraNETCC.com for more information.
Build 2747.42186, Serial# 00000a4d
Current time: 7/10/07 17:20:58
```

```
D) Display Settings
L) List Event Log
C) Send Email now
H) Hangup Globalstar Modem
B) Reset ExtraNET CC
F) Configure ExtraNET CC Mode
G) Configure Globalstar Modem
R) Show Communication Status
T) Test RTU Connection
```

### D) Display Settings:

```
Not connected
HEX GSN: 74040B82
Unit is pollable via SMS.
Local timezone is -6 hours from UTC.
SMTP IP Address: 63.247.209.118
SMTP TCP/IP Port: 25
E-Mail To Address: HermiesData@ExtraNETcc.com
E-Mail From Address: Globalstar@Neartime.com
E-Mail Subject: ExtraNET CC Data
No activity timeout: 10
Maximum Connect Time: 300
```

```
Globalstar baud rate: 9600
Terminal baud rate: 9600
Terminal port configured for RS232
```

```
Current Time is 23:22:15 8/29/07 UTC
```

The Display Settings will provide basic information about the unit's configuration. As shown in the above example the unit is configured to be pollable via SMS, and the time zone is set to UTC -6 which happens to be MST. Also shown is the email configuration which includes the SMTP server, SMTP port, To Address, From Address, and Subject. The unit is also configured to automatically hang up the modem if no data packets are sent for 10 seconds during a connection, and to automatically disconnect after a maximum of 300 seconds regardless of how much data is being sent. These features will help to save airtime if an unexpected error occurs. Also shown are the equipment baud rates and the current time.

For modems with a public dynamically assigned IP address, there are two different SMTP servers that may be used. The server at 63.247.209.118 (mail.extranetcc.com) is owned and maintained by Crystalline Technology and will trust any node on the Globalstar network. The server at 65.197.64.252 (smtp.pdn.globalstar.com) is operated by Globalstar and will also trust all Globalstar nodes. You must specify the actual IP number and not the domain.

## **L) List Event Log**

List Event Log displays a log of events that can be useful for troubleshooting and evaluating overall performance. As shown in the example above, the log shows information about satellite acquisition and loss. It also displays information about when the unit is transmitting data. If you are having trouble receiving data, the first place to look is the event log. All entries will have a timestamp as long as the time has been acquired from the satellite network at least once. The log has the capability of storing the last 100 events. Old events are automatically deleted as new ones are written. The event log can be cleared completely with the "F" command.

```
UTC Date   Time   Event
0/00/00   0:00:00 Connection Timed out
7/19/07   15:17:25 Initialize
7/19/07   15:20:15 Connection Timed out
7/19/07   15:20:38 Automatic Report
7/19/07   15:20:45 Connected
7/19/07   15:20:58 Disconnected
7/19/07   15:20:58 Connection Timed out
7/19/07   15:21:03 Connection Timed out
7/19/07   15:21:31 Satellite lost
7/19/07   15:23:32 Connection Timed out
7/19/07   15:26:13 Satellite Acquired
```

7/19/07 15:26:13 Automatic Report  
7/19/07 15:26:20 Connected  
0/00/00 0:00:00 Connection Timed out  
7/19/07 15:26:25 Initialize  
7/19/07 15:36:38 Satellite lost  
7/19/07 15:38:08 Satellite Acquired  
7/19/07 15:42:39 Satellite lost  
7/19/07 15:43:39 Satellite Acquired  
7/19/07 15:48:41 Satellite lost  
7/19/07 15:49:42 Satellite Acquired

### C) Send Email now

Scheduled at 7/12/07 13:40:09  
Hangup

Communication successful to FloBoss  
MeterTAG 23456  
Roc data ready

Establishing Connection CONNECT

MODEM RESP: CONNECTED  
Negotiating PPP...  
Connected to GlobalStar, IP Address is 10.162.58.159

Starting SMTP  
220-clf-smscl.ss.airtouch.com ESMTTP Sendmail  
8.13.7+Sun/8.13.7; Thu, 12 Jul 2007  
19:40:22 GMT  
220 We do not accept UCE.  
250 clf-smscl.ss.airtouch.com Hello [207.176.150.175],  
pleased to meet you  
250 2.1.0 <Globalstar@Neartime.com>... Sender ok  
250 2.1.5 <brian@neartime.com>... Recipient ok  
E250 2.0.0 16CJeM49008877 Message accepted for  
delivery

E-Mail Sent  
E221 2.0.0 clf-smscl.ss.airtouch.com closing  
connection

Message Accepted.

## Disconnecting hangup

The “C” command is used during installation and troubleshooting. It will poll the RTU for the most current data and then schedule a report to be sent via email using the current settings. The example above shows ExtraNET CC Avalanche polling a Fisher FloBoss for current data and then transmitting the report. Notice that ExtraNET CC Avalanche checks to see if coverage is available before attempting to transmit. If coverage is not available, you will see information from the AT\$QCSTATUS command scroll across the screen repeatedly until the unit can successfully transmit.

If Avalanche is unable to send the email due to a bad email address, SMTP server address, or a email server failure then Avalanche will disable future attempts to send email until the problem is corrected. Avalanche will also enter a mode where it stays awake for 24 hours continually checking for a SMS message that potentially will correct the problem.

Avalanche will also stay on line looking for a satellite until it is able to send the message. Proper installation with a good view of the sky will have a direct impact on the overall performance and the power requirements of Avalanche. This feature makes ExtraNET CC Avalanche very reliable in areas with little or no view of the sky, and makes use of any orbiting satellites which may be operating with degraded performance.

### **H) Hang-up Globalstar Modem**

This command is used to force the modem to hang up if it is currently on a phone call. This is useful for testing and diagnostics.

### **B) Reset ExtraNET CC**

Issuing the “B” command will force the processor to reset. This command is generally used only if the modem or processor board become erratic during initial testing. After completing the “F” command, the processor will also reset.

### **F) Configure ExtraNET CC Mode**

This is the command where the entire configuration takes place. Pressing the return key will advance you to the next configuration option. This can be quite complex and it is important to have a good idea of how you want to have the unit configured beforehand. Remember, to go on to the next option, simply press return. This is helpful if you miss something and need to issue the command again to get back to it.

The setup questions below are shown in Blue followed by an explanation.

Number of hours offset from UTC (-5 for EST) (-6)?

The time is acquired from the satellite. This provides a very accurate time standard which is used to determine when to poll and when to report. Since the satellite maintains time in the UTC (Universal Time Coordinated). Avalanche allows you to adjust this to your local time zone. EST is -5, CST is -6, MST is -7, PST is -8 and so on.

Allow unit to be polled via SMS? (Y) Set (Y)

SMS messages allow a convenient "out of band" method of sending commands to the Avalanche. If the SMS messages are enabled then the unit will not enter the low power mode and will stay awake waiting for SMS messages all the time. This is good if you want a polled solution. The unit will always stay awake for 3 minutes after sending an email allowing commands to be sent during that time.

Enable SMS security? (Y) Set (Y)

SMS messages present a potential security risk since the commands can cause things to happen, or cause them to quit happening. Avalanche has addressed this issue with a security that changes daily and is unique to the specific Avalanche. Enabling security is recommended.

Number of scheduled reports per day? (0) 1

For normal applications you should schedule at least one report per day to occur after contract hour.

WARNING: Schedule MUST be in increasing chronological order

and expressed in the configured time zone!

Schedule 1: Hour:Min:Sec (00:00:00) ? 07:00:00

You are entering times that are consistent with the UTC offset entered above. Enter the complete time in the format shown HH:MM:SS. The scheduler expect the times to be in the proper order as well. Use a 24 hour format with the times all in order (05:00:00 before 22:00:00).

Poll slave for Data? 1=No, 3=ROC, 4=Modbus Logger(ROC)

Avalanche will support both the ROC protocol and the MODBUS RTU protocol. Depending on your selection, you will be prompted for FloBoss parameters or MODBUS parameters.

ROC Master Group # (3)?

ROC Master Unit # (1)?

Avalanche acts as a ROC master. Although almost any address can be used, Group 3, Unit 1 is common for the ROCLINK 800 and similar hosts. It is also the default used with Avalanche.

ROC Remote Group # (240)?

ROC Remote Unit # (240)?

This is the address of the FloBoss that is connected to Avalanche. The group 240, unit 240 is a universal poll address for directly connected devices.

Operator ID (LOI)?  
Password (1000)?

If you are connected via the LOI port then you must specify a valid user name and password before access will be granted.

Report as record type (99)?

The record type is returned as part of the email message back to the host. If several different configurations are in use for different FloBoss units then the record type can be used to identify the type of data contained in the email. This is particularly useful for binary messages.

SMTP IP Address is 63.247.209.118  
Change IP address (N)? , Enter new address:  
BYTE0: 65  
BYTE1: 197  
BYTE2: 64  
BYTE3: 252

**WARNING: There are two public email servers (SMTP) that are available for use with Avalanche. 63.247.209.118 (mail.extranetcc.com) operated by Crystalline Technology and 65.197.64.252 (smtp.pdn.globalstar.com) both are configured to accept messages from within the Globalstar network. For devices configured with a static IP, you will need to provide the address of your server.**

SMTP PORT (25):

**WARNING: Port 25 is the standard port used for SMTP mail servers. Change this only if you have a mail server that operates on a different, not standard port.**

E-Mail To Address (HermiesData@ExtraNETcc.com):  
E-Mail From Address (Globalstar@Neartime.com):  
E-Mail Subject (ExtraNET CC Data):

**WARNING: The email To, From, and Subject lines are configured here. Please note, if you provide a invalid email address (or SMTP server above), it will be impossible to send the data and may result in a unit that is totally non-functional without a field visit to correct the configuration.**

Send attachment as binary? (Y) or CSV (N)? (N) Set (N)  
Data can be returned in the email as standard CSV (comma delimited file) or as a binary file.

Maximum amount of NO ACTIVITY time (10 seconds)?  
Absolute maximum time allowed for connection? (300)

For Avalanche these parameters should not be changed without consultation with Crystalline Technology.

Use RS232 (Y) or RS485 (N)? (Y) Set (Y)

The interface used to communicate with the RTU supports both an RS-232 and a RS-485 style interface. You must match the selection with the interface on the RTU.

Baud Rate for local Terminal / RTU (9600)?

9600 baud is highly recommended unless you have an RTU that will not operate at this baud rate.

Clear event log? (contains 250 events) (Y)

Setup Complete, Restarting

After completing the configuration, Avalanche will perform a reset so all the new setting will take effect.

## ***Email Attachment Formats***

### **Binary File - FloBoss**

Selecting the “Binary” file format will cause Avalanche to send the attachment as a binary “ATT” file. This file must be parsed with a user supplied program. For purposes of sending the data using e-mail, the data is mime BASE64 encoded in accordance to RFC2045

```
// RFC2045 describes the mime base64 encoding that allows  
// transfer of binary data through an ASCII channel.
```

Table 1: The Base64 Alphabet

Value	Encoding	Value	Encoding	Value	Encoding	Value	Encoding
0	A	17	R	34	i	51	z
1	B	18	S	35	j	52	0
2	C	19	T	36	k	53	1
3	D	20	U	37	l	54	2
4	E	21	V	38	m	55	3
5	F	22	W	39	n	56	4
6	G	23	X	40	o	57	5
7	H	24	Y	41	p	58	6
8	I	25	Z	42	q	59	7
9	J	26	a	43	r	60	8
10	K	27	b	44	s	61	9
11	L	28	c	45	t	62	+
12	M	29	d	46	u	63	/
13	N	30	e	47	v		
14	O	31	f	48	w	(pad)	=
15	P	32	g	49	x		
16	Q	33	h	50	y		

```
//See a definition of the mapping requirement at the following URL:
//http://www.cse.ohio-state.edu/cgi-bin/rfc/rfc1521.html#sec-5.2
```

```
// The record structure for doing a binary file attachment
// the structure "assumes" that you are using a properly defined
// configuration in the FloBoss
```

```
typedef struct _API{
    ieee Time;
    ieee FlowTime;
    ieee Hw;
    ieee Pf;
    ieee Tf;
    ieee IMV;
    ieee hwpf;
    ieee Vol;
    ieee Energy;
    ieee BTU;
    ieee SG;
    ieee CO2;
    ieee N2;
    ieee MaxHw;
    ieee MinHw;
    ieee MinBatt;
} API;

typedef union _history{
    api byName;
    ieee v[16];
} History; // record is 64 bytes long

typedef struct {
    int      Message_Type;           // specified during
                                     // configuration
    int32    RTU_ID;                 // a 32 bit RTU Tag # (must be
                                     // numeric)
    ieee     Analog1;                // FloBoss Analog1
    ieee     Analog2;                // FloBoss Analog2
    ieee     Analog3;                // FloBoss Analog3
    int32    TOD;                    // Genesis is 1/1/2000
    History  Daily;                  // 16 values from daily archive
    History  Hourly[24];             // 16 values from the hourly /
                                     // Extended archive
} _rocddata; // record is 1621 bytes long
```

A sample file:

offset	data	description
00000	63	// Message Type
00001	A0 5B 00 00	// RTU_ID (Big Ended, word reversed Intel format)
		// 23456
00005	00 00 20 41	// Analog1 (IEEE754) 10.0
00009	00 00 A0 41	// Analog2 (IEEE754) 20.0
0000D	1A D0 E6 40	// Analog3 (IEEE754) 7.2129

```

00011 76 58 C4 08 // TOD (#seconds since 1/1/200)
00015 00 0A 1E 08 // Daily (MM:HH DD:MM) Sept 30, 10:00 AM
00019 00 00 B4 44 // Daily Flow time (minutes) 1440.0
0001D 00 00 70 42 // Daily average Hw 60.0
00021 00 80 BB 43 // Daily average Pf 375.0
00025 00 00 82 42 // Daily average Tf 65.0
00029 F2 EE D5 44 // Daily IMV 1711.467
0002D 56 DA 18 43 // Daily hwpf 152.8529
00031 B6 33 C4 45 // Daily Volume 6278.464
00035 7E 87 C9 45 // Daily Energy 6448.937
00039 00 00 00 00 // Daily Column 9 0.0
0003d 00 00 00 00 // Daily Column 10 0.0
00041 00 00 00 00 // Daily Column 11 0.0
00045 00 00 00 00 // Daily Column 12 0.0
00049 53 4E 27 01 // Calculated Minimum Extended Column 1 3E-38
0004d 00 00 00 00 // Calculated Maximum Extended Column 2 0.0
00051 00 00 00 00 // Calculated Minimum Extended Column 3 0.0
00055 00 0C 1D 08 // Hourly Time Stamp Sept 29, 12:00 PM
00059 00 00 70 42 // Hourly Flow Time 60.0
0005d 00 00 70 42 // Hourly average hw 60.0
00061 00 80 BB 43 // Hourly average Pf 375.0
00065 00 00 82 42 // Hourly average Tf 60.0
00069 F2 EE D5 44 // Hourly IMV 1711.467
0006d 56 DA 18 43 // Hourly hwpf 152.8529
00071 24 CD 82 43 // Hourly Volume 261.6027
00075 54 5A 86 43 // Hourly Energy 268.7057
00079 00 00 00 00 // Hourly column 9 0.0
0007d 00 00 00 00 // Hourly column 10 0.0
00081 00 00 00 00 // Hourly column 11 0.0
00085 00 00 00 00 // Hourly column 12 0.0
00089 00 00 00 00 // Extended column 1 0.0
0008d 00 00 00 00 // Extended column 2 0.0
00091 00 00 00 00 // Extended column 3 0.0
00095 00 0D 1D 08 // Hourly record #2 time stamp
00099 00 00 70 42 // Hours 2 through 24 repeat the format described
0009d 00 00 70 // above...
000A0 42 00 80 BB 43 00 00 82 42 F2 EE D5 44 56 DA 18
000B0 43 24 CD 82 43 54 5A 86 43 00 00 00 00 00 00 00
000C0 00 00 00 00 00 00 00 00 00 00 00 00 00 00 00
000D0 00 00 00 00 00
000D5 00 0E 1D 08 00 00 70 42 00 00 70 // Hour 3
000E0 42 00 80 BB 43 00 00 82 42 F2 EE D5 44 56 DA 18
000F0 43 24 CD 82 43 54 5A 86 43 00 00 00 00 00 00 00
00100 00 00 00 00 00 00 00 00 00 00 00 00 00 00
00110 00 00 00 00 00
00115 00 0F 1D 08 00 00 70 42 00 00 70 // Hour 4
00120 42 00 80 BB 43 00 00 82 42 F2 EE D5 44 56 DA 18
00130 43 24 CD 82 43 54 5A 86 43 00 00 00 00 00 00 00
00140 00 00 00 00 00 00 00 00 00 00 00 00 00 00
00150 00 00 00 00 00
00155 00 10 1D 08 00 00 70 42 00 00 70 // Hour 5
00160 42 00 80 BB 43 00 00 82 42 F2 EE D5 44 56 DA 18
00170 43 24 CD 82 43 54 5A 86 43 00 00 00 00 00 00 00
00180 00 00 00 00 00 00 00 00 00 00 00 00 00 00
00190 00 00 00 00 00
0019d 00 11 1D 08 00 00 70 42 00 00 70 // Hour 6
001A0 42 00 80 BB 43 00 00 82 42 F2 EE D5 44 56 DA 18
001B0 43 24 CD 82 43 54 5A 86 43 00 00 00 00 00 00 00
001C0 00 00 00 00 00 00 00 00 00 00 00 00 00 00
001D0 00 00 00 00 00
001d5 00 12 1D 08 00 00 70 42 00 00 70 // Hour 7
001E0 42 00 80 BB 43 00 00 82 42 F2 EE D5 44 56 DA 18
001F0 43 24 CD 82 43 54 5A 86 43 00 00 00 00 00 00 00

```

```

00200 00 00 00 00 00 00 00 00 00 00 00 00 00 00 00
00210 00 00 00 00 00
00215 00 13 1D 08 00 00 70 42 00 00 70 // Hour 8
00220 42 00 80 BB 43 00 00 82 42 F2 EE D5 44 56 DA 18
00230 43 24 CD 82 43 54 5A 86 43 00 00 00 00 00 00 00
00240 00 00 00 00 00 00 00 00 00 00 00 00 00 00 00
00250 00 00 00 00 00
00255 00 14 1D 08 00 00 70 42 00 00 70 // Hour 9
00260 42 00 80 BB 43 00 00 82 42 F2 EE D5 44 56 DA 18
00270 43 24 CD 82 43 54 5A 86 43 00 00 00 00 00 00 00
00280 00 00 00 00 00 00 00 00 00 00 00 00 00 00 00
00290 00 00 00 00 00
0029f 00 15 1D 08 00 00 70 42 00 00 70 // Hour 10
002A0 42 00 80 BB 43 00 00 82 42 F2 EE D5 44 56 DA 18
002B0 43 24 CD 82 43 54 5A 86 43 00 00 00 00 00 00 00
002C0 00 00 00 00 00 00 00 00 00 00 00 00 00 00 00
002D0 00 00 00 00 00
002D5 00 16 1D 08 00 00 70 42 00 00 70 // Hour 11
002E0 42 00 80 BB 43 00 00 82 42 F2 EE D5 44 56 DA 18
002F0 43 24 CD 82 43 54 5A 86 43 00 00 00 00 00 00 00
00300 00 00 00 00 00 00 00 00 00 00 00 00 00 00 00
00310 00 00 00 00 00
00315 00 17 1D 08 00 00 70 42 00 00 70 // Hour 12
00320 42 00 80 BB 43 00 00 82 42 F2 EE D5 44 56 DA 18
00330 43 24 CD 82 43 54 5A 86 43 00 00 00 00 00 00 00
00340 00 00 00 00 00 00 00 00 00 00 00 00 00 00 00
00350 00 00 00 00 00
00355 00 00 1E 08 00 00 70 42 00 00 70 // Hour 13
00360 42 00 80 BB 43 00 00 82 42 F2 EE D5 44 56 DA 18
00370 43 24 CD 82 43 54 5A 86 43 00 00 00 00 00 00 00
00380 00 00 00 00 00 00 00 00 00 00 00 00 00 00 00
00390 00 00 00 00 00
00395 00 01 1E 08 00 00 70 42 00 00 70 // Hour 14
003A0 42 00 80 BB 43 00 00 82 42 F2 EE D5 44 56 DA 18
003B0 43 24 CD 82 43 54 5A 86 43 00 00 00 00 00 00 00
003C0 00 00 00 00 00 00 00 00 00 00 00 00 00 00 00
003D0 00 00 00 00 00
003D5 00 02 1E 08 00 00 70 42 00 00 70 // Hour 15
003E0 42 00 80 BB 43 00 00 82 42 F2 EE D5 44 56 DA 18
003F0 43 24 CD 82 43 54 5A 86 43 00 00 00 00 00 00 00
00400 00 00 00 00 00 00 00 00 00 00 00 00 00 00 00
00410 00 00 00 00 00
00415 00 03 1E 08 00 00 70 42 00 00 70 // Hour 16
00420 42 00 80 BB 43 00 00 82 42 F2 EE D5 44 56 DA 18
00430 43 24 CD 82 43 54 5A 86 43 00 00 00 00 00 00 00
00440 00 00 00 00 00 00 00 00 00 00 00 00 00 00 00
00450 00 00 00 00 00
00455 00 04 1E 08 00 00 70 42 00 00 70 // Hour 17
00460 42 00 80 BB 43 00 00 82 42 F2 EE D5 44 56 DA 18
00470 43 24 CD 82 43 54 5A 86 43 00 00 00 00 00 00 00
00480 00 00 00 00 00 00 00 00 00 00 00 00 00 00 00
00490 00 00 00 00 00
00495 00 05 1E 08 00 00 70 42 00 00 70 // Hour 18
004A0 42 00 80 BB 43 00 00 82 42 F2 EE D5 44 56 DA 18
004B0 43 24 CD 82 43 54 5A 86 43 00 00 00 00 00 00 00
004C0 00 00 00 00 00 00 00 00 00 00 00 00 00 00 00
004D0 00 00 00 00 00
004D5 00 06 1E 08 00 00 70 42 00 00 70 // Hour 19
004E0 42 00 80 BB 43 00 00 82 42 F2 EE D5 44 56 DA 18
004F0 43 24 CD 82 43 54 5A 86 43 00 00 00 00 00 00 00
00500 00 00 00 00 00 00 00 00 00 00 00 00 00 00 00
00510 00 00 00 00 00
00515 00 07 1E 08 00 00 70 42 00 00 70 // Hour 20

```

```

00520 42 00 80 BB 43 00 00 82 42 F2 EE D5 44 56 DA 18
00530 43 24 CD 82 43 54 5A 86 43 00 00 00 00 00 00
00540 00 00 00 00 00 00 00 00 00 00 00 00 00 00
00550 00 00 00 00 00
00555 00 08 1E 08 00 00 70 42 00 00 70 // Hour 21
00560 42 00 80 BB 43 00 00 82 42 F2 EE D5 44 56 DA 18
00570 43 24 CD 82 43 54 5A 86 43 00 00 00 00 00 00
00580 00 00 00 00 00 00 00 00 00 00 00 00 00 00
00590 00 00 00 00 00
00595 00 09 1E 08 00 00 70 42 00 00 70 // Hour 22
005A0 42 00 80 BB 43 00 00 82 42 F2 EE D5 44 56 DA 18
005B0 43 24 CD 82 43 54 5A 86 43 00 00 00 00 00 00
005C0 00 00 00 00 00 00 00 00 00 00 00 00 00 00
005D0 00 00 00 00 00
005D5 00 0A 1E 08 00 00 70 42 00 00 70 // Hour 23
005E0 42 00 80 BB 43 00 00 82 42 F2 EE D5 44 56 DA 18
005F0 43 24 CD 82 43 54 5A 86 43 00 00 00 00 00 00
00600 00 00 00 00 00 00 00 00 00 00 00 00 00 00
00610 00 00 00 00 00
00615 00 0B 1E 08 00 00 70 42 00 00 70 // Hour 24
00620 42 00 80 BB 43 00 00 82 42 F2 EE D5 44 56 DA 18
00630 43 24 CD 82 43 54 5A 86 43 00 00 00 00 00 00
00640 00 00 00 00 00 00 00 00 00 00 00 00 00 00
00650 00 00 00 00 00

```

## Comma Delimited File Format – FloBoss

The CSV file format is a user friendly format that can easily be loaded into most databases such as MS Sql, MySql, and Access, or in to spread sheets such as Excel. Each string is encapsulated in quotation marks and each data field is separated with a comma.

For both the Daily and Hourly records, zeros will be included if the user has not defined the optional columns as described below. The optional columns are included to support special requirements such as logging of casing and tubing pressure, perhaps compressor status, tank levels, and other operational sensors can be used as well. This provides a very high degree of flexibility while maintaining a very simple and standardized data reporting system to be used.

It is suggested that you match a “record type” to an user defined FloBoss configuration when configuring the Avalanche.

There are 6 possible record formats included with each email. Column A contains the record format for that row. The possible formats are:

**Node Info:** (contains basic information about the FloBoss and ExtraNET)

- Column B – Time record was acquired from the FloBoss
- Column C – The unique Electronic Serial Number of the ExtraNET that originated the message
- Column D – The Meter Tag number from the FloBoss (point 41,0,0)
- Column E – User defined format type as set during configuration
- Column F – Analog 1
- Column G- Analog 2

- Column H – Analog 3
- Column I – FloBoss Battery Voltage

**Definitions:** (contains header names for the current, daily, and hourly records) The header names are derived by reading the definition of the hourly and extended tables. The numbers represented are the basic TLP identifiers used to define the points being logged.

**Current:** (snap shot) After reading the definitions above, Avalanche then polls each one of the TLP points to see what the current reading is. Thus, if you are logging average Hw (differential pressure) in the hourly history, you will see a entry in the “Current:” row that has the instantaneous Hw at the time the data was polled from the FloBoss

**Daily:** The first 12 columns of the Daily archive are returned of the most recent record in the archive. This is the record for the previous day.

- Column B – Month, Day, Hour, and Minute of record. Microsoft Excel automatically interprets this data for the correct year.
- Columns C to J are the first 8 default data items logged by the FloBoss which are in compliance with API21.1
- Columns K to N are the next 4 user defined columns in the Daily Archive
- Column O is the minimum of the first column in the Extended archive for the most recent 24 hours. This is useful for recording things like the minimum differential pressure experienced over the last 24 hours.
- Column P is the maximum of the second column in the Extended archive for the most recent 24 hours. This could record things such as the maximum differential pressure experienced over the last 24 hours.
- Column Q is the minimum of the third column in the Extended archive for the most recent 24 hours. Typically this would be minimum battery voltage over the last 24 hours.

**Hourly:** The most recent 24 hourly records read from the Hourly and Extended archives. The first 8 columns of the hourly archive are defined by the FloBoss to be in accordance to API 21.1 guidelines. An additional 4 user defined columns are included along with the first 3 columns of the Extended archive.

**Event:** Due to the very comprehensive and compact recording of events in the FloBoss, Avalanche simply reads all the new events and sends them as ASCII encoded hex. It is up to the user to decode these events in accordance to the ROC Protocol Users Manual available from Emerson / Fisher.

Avalanche maintains a pointer so that only new events are sent each time.

**Configuration:** Any time that the configuration is changed, Avalanche will send a complete new configuration back to the host. This configuration contains some 42 different items that have been identified as having affect over the way that volumes are being calculated.

- Columns B through AQ correlate to Point Type 46, parameters 2 to 43 in order. Please refer to the ROC Protocol User Manual for more information on how to decode these numbers. Any binary (BIN) are encoded as ASCII HEX.

## SMS Messages

SMS (Short Message Service) is a method of sending short ASCII commands to the ExtraNET Avalanche. SMS messages are typically used as a method of sending text messages to telephones. In the case of Avalanche they present some quite interesting attributes.

- They are available with most Globalstar gateways and always available if you roam from a US or Canada account.
- SMS messages allow 30 to 35 bytes or more of text (varies according to gateway).
- SMS messages are queued until the unit has satellite coverage and registers on a gateway.
- SMS messages are FREE and can be sent from any Globalstar SMS portal. See <http://globalstarusa.com/en/services/enhancedservices/g2sms.php>

Since it is so easy to send SMS messages, Avalanche has a method of securing the message. Turn on the SMS security during configuration and Avalanche will only respond to SMS messages that have a special security code attached to the message. The security code is different for each unit and changes every day.

Avalanche can be configured to check for SMS messages at all times (at the cost of increased power consumption) or only after it has sent an email. Since most Avalanche devices are configured to send an e-mail at least once per day and the gateway will queue the message, there is always an opportunity to issue commands, if you are not in a hurry.

There are several commands that Avalanche can respond to. These commands include:

- “ON:” Turn on the SMS check. This will cause Avalanche to check for SMS messages every 10 seconds. Power consumption will be much greater when in this mode.
- “OFF:” Turn off the SMS check and enter the low power mode.
- “TO:email@domain.com” Command Avalanche to send a report now to the specified email address. This address will become the default address for future normally scheduled emails.
- “IP:0.0.0.0” Sent an email to the last email address that was used.
- “SMTP:xx.xx.xx.xx” Change the SMTP server used to send messages to the specified IP address.
- Send configuration changes to the Avalanche. Please contact Crystalline for more information concerning these very sensitive commands.
- “BINARY:” Send ROC or MODBUS messages to the attached RTU

## **SMS Support Program**

A special application is provided by Crystalline Technology to facilitate sending of messages. You can download the utility from [http://www.Crystalline.us/downloads/ExtraNET/SMS/Poll\\_ExtraNET.zip](http://www.Crystalline.us/downloads/ExtraNET/SMS/Poll_ExtraNET.zip) and run the setup program to install it on your computer.

The first time you use the Poll\_ExtraNET program you should set your host IP address. It will retain this for future use. In order for Poll\_ExtraNET to work, the computer it is used on must have access to the Internet. The program automates the process normally required to send an SMS message from the [www.Globalstarusa.com](http://www.Globalstarusa.com) web site.

The Poll\_ExtraNET program works with all models of ExtraNET. You can enter a phone number for the ExtraNET if known, or you can enter the IP if it is using a static IP address. For units that are configured for “secure SMS” you must know the HEX ESN (Electronic Serial Number) of the unit you are sending the message to. The HEX ESN is found on a label on the QUALCOMM modem.

The email that is sent to the host contains the ESN as well if you are using the FloBoss data collection. If you are using the MODBUS then you may contact us for more information.

## ExtraNET $\mu$ CC Overview

The Crystalline Technology, Inc. "ExtraNET  $\mu$ CC" (micro CC) provides a turn key solution for two way data communications using the Globalstar satellite network.

The ExtraNET  $\mu$ CC is packaged in a rugged die cast watertight aluminum enclosure meeting NEMA 4X IP 66, EN60529 specifications. Combined with the exceptional operating range and flexible mounting system, ExtraNET CC is ideally suited for outdoor use in extreme field conditions and locations. ExtraNET  $\mu$ CC has weather proof "O-Ring" connectors for easy installation.

The ExtraNET  $\mu$ CC processor monitors the Globalstar modem and provides re-initialization and self monitoring to provide reliable communications to remote facilities. Easy configuration allows for up to 8K bytes of initialization strings to satisfy virtually any setup requirements you might have. The "watch dog" times all active satellite sessions and will automatically disconnect if you exceed your predetermined maximum allowed connection to prevent expensive "hung sessions" on the Globalstar network.

### Product Highlights:

- Automatic detection of modem reset and re-initialization of user configuration
- Call timer and user configurable maximum allowed connection
- Menu driven easy configuration using terminal type program (ie. HyperTerminal)
- 8K bytes of nonvolatile flash memory for initialization commands
- Rugged die cast Aluminum Enclosure
- Weather proof electrical connections
- Low Power operation
- Extended Temperature Range
- Functional in over 100 countries for coverage in most countries world wide
- 1 year warrantee
- Complete support for assuring successful integration in your application
- Part of a complete line of products offered by Crystalline Technology, Inc.

### Specifications:

Operating Range: -30C to 60C (-40F to 185F)

Storage Range: -40 to 85C

Dimensions: 7.95" x 11.88" x 4.37" (with Teacup Antenna)

7.95" x 16.13" x 4.37" (with Mini-Stick Antenna)

Operating Voltage: 5.6 VDC to 16 VDC

Operating Current: 0.5W Receive

5.4W Transmit

Data Rate: 9600 Baud (Satellite)  
300 to 115,200 Baud (user)  
9600 Configuration  
Operating Frequency: 1610 – 1625 MHz (transmit)  
2484 – 2499 MHz (receive)

## **ExtraNET $\mu$ CC Configuration**

To configure the ExtraNET  $\mu$ CC you connect the DB9 to Phoenix 4 pin cable to both the ExtraNET  $\mu$ CC controller and a computer such as a lap top. HyperTerminal when configured to 19200 baud, 8 bits, no parity, and no handshake will work fine. You can press the space bar to receive the menu.

- L) List AT initialization commands
- C) Clear all AT initialization commands
- E) Enter new AT initialization commands
- S) Set maximum connect time
- T) Test initialization commands
- H) Help

Command>

Standard "AT" modem commands can be entered into the  $\mu$ CC. Upon detection of a reset or power up condition these commands will be sent to the modem. The  $\mu$ CC requires that the modem respond with the result code of "OK" for each command. If the modem does not respond with the expected "OK" the  $\mu$ CC will try to send the command again.

In order to enter the commands that you want sent to the modem upon power up or reset simply enter the letter "E". The ExtraNET  $\mu$ CC has 8192 bytes of non-volatile flash memory. This memory has a retention time of greater than 100 years and can be rewritten 100,000 times or more. It would take a very unusual application to come close to taxing the memory of ExtraNET  $\mu$ CC. Typical commands might be:

Enter each command on a line by itself, empty line to end.

```
>ath
>atz
>at$qcpknd=1
>ats0=1
>
```

You can display the commands currently saved in non-volatile memory with the "L" command:

```
ath
atz
at$qcpknd=1
ats0=1
```

Command>

The “S” command allows you to establish a limit to how long you will allow the modem to be connected. Since Globalstar is a time based system instead of a data based bill, it is important to disconnect when ever you have periods greater than a few seconds. The ExtraNET  $\mu$ CC monitors the DCD (Data Carrier Detect) line for connections. When ever the DCD line has been active for the time entered the ExtraNET  $\mu$ CC will take over control and send the initialization string to the modem. Hence the desire to always start your commands with the ATH command. A typical setting allowing for 5 minutes would be entered as shown below:

```
Command>  
Max Connect Time? (65535 seconds) 300
```

The “T” command allows you to test the ExtraNET  $\mu$ CC commands to assure that they achieve the desired result. You will see each command that is sent to the modem followed by the response received from the modem. If you do not see the “OK” then you have an improper command that is being sent to the modem. Since ExtraNET  $\mu$ CC makes every effort to assure that the commands are sent and received by the modem, a bad command will cause the ExtraNET  $\mu$ CC to enter a loop where it simply tries over and over again. See the section “Obtaining Control of ExtraNET  $\mu$ CC”

“H” will provide a short description of ExtraNET  $\mu$ CC.

### ***Obtaining Control of ExtraNET $\mu$ CC***

If for any reason the unit gets into a loop of continuing to retry the commands but the modem is refusing to respond with the “OK” you have the option of overriding the normal long and getting back to the menu.

This is done by holding a jumper such as a paper clip on the 10 pin phoenix connector and jumpering pins 7 and 9 (labeled AI4 and AI5) while you apply power to the unit.

This will result in the menu being shown and giving you the option of “C” clearing the existing commands and “E” entering new and proper commands.

### ***Installation of ExtraNET $\mu$ CC***

ExtraNET  $\mu$ CC is packaged in a rugged cast aluminum or fiberglass NEMA4 enclosure suitable for out door installation in harsh environments. A suitable structure capable of supporting the ExtraNET  $\mu$ CC must be provided by the customer. Such a structure should allow the ExtraNET  $\mu$ CC’s antenna to have un obstructed view of the sky. The Globalstar satellites are in low earth orbit (LEO) and will move across the sky in various orbits and directions. The better the view of the sky the greater your chances of making contact at any given moment are.

There is a rubber gasket along the perimeter of the enclosure. To maintain the seal it is very important that the lid be properly aligned on the gasket and firmly secured. The connectors on the bottom of the unit are water tight and include an O-Ring seal to maintain integrity.

### ***Integrating ExtraNET $\mu$ CC into an application***

As a flexible communications device, ExtraNET  $\mu$ CC can be integrated in to a wide diversity of applications. To understand all the various aspects of the unit requires a good understanding of serial data, satellite coverage, activation, and various environmental issues related to the Globalstar GSP-1620 data modem. Crystalline Technology makes the “Integrators Reference Manual” available for download at [http://www.Crystalline.us/documentation/GSP1620\\_Int\\_Ref\\_Manual.pdf](http://www.Crystalline.us/documentation/GSP1620_Int_Ref_Manual.pdf).

## **ExtraNET $\mu$ CC Wiring Requirements**

ExtraNET  $\mu$ CC has separate connectors for power and data. Power is provided to the unit through a 2 pin Conxall plug (part # 6282-2SG-3DC). Positive is on pin 1 and ground is on pin 2. The power requirements are +5.6 V to +16 V DC at 1 Amp. You will know that the unit is up and running when the red LED on the controller board begins to blink once every second.

RS-232 serial data is provided on the 8 pin Conxall (part # 6282-8PG-3DC) and has the following pin out:

Name	Direction	Conxall (DCE)	DB9F (PC) (DTE)	Description
Ground		1	5	Ground Return
DSR	DTE <- DCE	2	6	Data Set Ready
CTS	DTE <- DCE	3	8	Clear To Send
RTS	DTE -> DCE	4	7	Request To Send
RXD	DTE -> DCE	5	2	Receive Data
TXD	DTE <- DCE	6	3	Transmit Data
DCD	DTE <- DCE	7	1	Data Carrier Detect
DTR	DTE -> DCE	8	4	Data Terminal Ready

**For proper operation, it is required that the DTR and RTS be at a “high” state before the unit will respond.** It is common practice to connect RTS to CTS and then control the power to the unit via the DTR line. When DTR is low, the modem will be placed into a low power mode and the system will consume approximately 15mA. When DTR is high, the power will fluctuate between 70 mA and 200 mA in the receive “stand by” mode (averaging approximately 150 mA).

### **Terminal strip inside the ExtraNET $\mu$ CC enclosure:**

- 1: Ground – Blue
- 2: DSR (Data Set Ready) – Not Connected
- 3: CTS (Clear To Send) – Jumper to RTS
- 4: RTS (Request To Send) – Jumper to CTS
- 5: RXD (Received Data) – Green
- 6: TXD (Transmitted Data) – White
- 7: DCD (Data Carrier Detect) – Not Connected

8: DTR (Data Terminal Ready) - Yellow  
9: - Ground - Black  
10: + 12V - Red  
11: Not Used  
12: Not Used

# Appendix A – UL Certification

## MET LABORATORIES, INC. CLASSIFICATION RECORD



*The applicant named below has been authorized by MET Laboratories, Inc. to represent the product(s) listed in this record as "MET Classified" and to mark this/these product(s) according to the terms and conditions of the MET Mark Utilization Agreement, MET Listing Reports, and the applicable marking agreements. Only the product(s) bearing the MET Mark and under a follow-up service are considered to be included in the MET Classification program.*

**FILE NUMBER:** E112660      **APPROVAL DATE:** April 6, 2007  
**REVISED:** -

PRODUCT(S)	MODEL(S)	ELECTRICAL RATINGS
Gas Communications Controller	ExtraNET CC	8-15 VDC @ 2 Amps, Class I Division 1, Group D, T4

STANDARD NUMBER	STANDARD TITLE	EDITION
UL913	Safety for intrinsically safe apparatus and associated apparatus for use in Class I, II and III, Division 1, Hazardous (Classified) locations	6 <sup>th</sup>
CSA C22.2 No 157	Intrinsically safe and non-incendive equipment for use in Hazardous locations	1992

MET LABORATORIES, INC. requires that any and all changes proposed in the previously identified product(s), that affects the information contained in the above referenced listing report, must be submitted to MET for evaluation prior to implementation to assure continued MET Classification status.

The above identified product(s) has/have been submitted by the applicant:

**APPLICANT:**  
Crystalline Technology, Inc.  
P. O. Box 8423  
Pueblo, CO 81008-8423

The covered products shall be subjected to quarterly follow-up inspections to ensure that the Classified product(s) are identical to the representative product sample evaluated by MET LABORATORIES, INC. and that all manufacturer's responsibilities are being fulfilled as specified in the MANUFACTURING RESPONSIBILITY section of the Certification report.

  
Rick Cooper  
Director of Laboratory Operations,  
Safety Laboratory



*MET Laboratories, Inc. is accredited by OSHA and the Standards Council of Canada.  
The Nation's First Nationally Recognized Testing Laboratory*



## ***Special Instructions for Class I, Division 2 Hazardous Locations***

- 1) Crystalline Technology, Inc.'s ExtraNET CC is listed by MET Laboratories (MET) as non-incendive and is suitable for Class I, Division 2, Group C and D hazardous locations or nonhazardous locations only. Read this document carefully before installing a nonincendive ExtraNET CC. Refer to the User's Manual for general information. In the event of a conflict between the ExtraNET CC User's Manual and this document, always follow the instructions in this document.
- 2) The ExtraNET CC includes both nonincendive and unrated field circuits. Unless a circuit is specifically identified in this document as nonincendive, the circuit is unrated. Unrated circuits must be wired using Division 2 wiring methods as specified in article 501-4(b) of the National Electrical Code (NEC), NFPA 70 for installations in the United States, or as specified in Section 18-152 of the Canadian Electrical Code for installation in Canada.
- 3) The communication ports terminate in a Phoenix connector on the inside of the ExtraNET CC enclosure. The wiring to this connector is unrated. No connections may be made to this port unless the user ensures that the area is known to be nonhazardous. Connections to this port are temporary, and must be short in duration to ensure that flammable concentrations do not accumulate while it is in use.
- 4) The optional power system (solar panel and battery) approved for use with the nonincendive ExtraNET CC are described in the model specification. The connection to the solar panel is approved as a nonincendive circuit so that Division 2 wiring methods are not required. The nominal panel voltage must match the nominal battery voltage (12V).
- 5) **WARNING: EXPLOSION HAZARD – Do Not disconnect Solar Power from the Battery or any other power connections within the ExtraNET CC enclosure (including connectors J1 through J6) on the system controller module or any power connections to items such as the GSP-1620 modem unless the area is known to be nonhazardous.**
- 6) **WARNING: EXPLOSION HAZARD – Substitution of major components may impair suitability for use in Class 1, Division 2 environments**
- 7) **WARNING: EXPLOSION HAZARD – Do not disconnect equipment unless power has been disconnected and the area is known to be nonhazardous**
- 8) **WARNING: EXPLOSION HAZARD – The area must be known to be nonhazardous before servicing/replacing the unit and before installing or removing I/O wiring.**
- 9) Signal connectors available for customer wiring are unrated and must be wired using Division 2 wiring methods.

## Specifications:

### **Satellite Network:**

Integrated Globalstar 1620 digital modem.

### **Optional Cellular Network:**

GSM / GPRS, Edge, 1X, or CDMA cellular service providers

### **Coverage Area:**

Virtually anywhere in the world where a view of the sky is available

### **Power Requirements:**

+5.6 V to +14.5 V

1 W typical

6.0 W Max Transmit

### **Dimensions:**

6 in depth 9 in width 18 height, with vertical antenna included

### **Environmental Conditions:**

Operating -30 to +60 C

Storage -40 to +85 C

### **Customer Interface:**

RS232 or RS485 (user selectable) at 110, 300, 2400, 9600, 19200, 38400, 57600, or 115200 baud

5 I/O points with 10 bit A/D (0 to 5VDC) input or digital output (0 to 5VDC @ 20mA)

### **Host Protocols Supported:**

TCP, UDP, ICMP, Modbus/IP

### **Network:**

Via Static IP using VPN direct to Globalstar NOC or via our secure gateway available on the Internet

## Contact Information

### Corporate Offices:

Physical address:  
Crystalline Technology, Inc.  
67 N. Silicon Dr. Suite 150  
Pueblo West, CO 81007

All correspondence should be addressed to:  
Crystalline Technology, Inc.  
PO Box 8423  
Pueblo, CO 81008

Tel: (719) 543-2577  
Fax: (719) 543-2578  
Toll free: (888) 737-9817

Web page: <http://www.ExtraNETcc.com>  
Email: [support@extranetcc.com](mailto:support@extranetcc.com)